

**TECHNICAL MANUAL**

**OPERATOR'S, ORGANIZATIONAL, DIRECT SUPPORT AND  
GENERAL SUPPORT MAINTENANCE MANUAL  
INCLUDING REPAIR PARTS AND SPECIAL TOOLS LIST**

**RECORDER R0-458(V)1/U  
(HEWLETT-PACKARD MODEL HP-7035B)  
(NSN 6625-00-463-6042)**

*This manual contains copyright material reproduced by permission of the HEWLETT-PACKARD company.*

TECHNICAL MANUAL }  
 No. 11-6625-2850-14&P }

HEADQUARTERS  
 DEPARTMENT OF THE ARMY  
 WASHINGTON, DC, 28 April 1982

**OPERATOR'S, ORGANIZATIONAL, DIRECT SUPPORT AND  
 GENERAL SUPPORT MAINTENANCE MANUAL  
 INCLUDING REPAIR PARTS AND SPECIAL TOOLS LIST  
 RECORDER R0-458(V)1/U  
 HEWLETT-PACKARD MODEL HP-7035B  
 (NSN 6625-00-463-6042)**

**REPORTING ERRORS AND RECOMMENDING IMPROVEMENTS**

You can help improve this manual. If you find any mistakes or if you know of a way to improve the procedures, please let us know. Mail your letter, DA Form 2028 (Recommended Changes to Publications and Blank Forms), or DA Form 2028-2 located in back of this manual direct to Commander, US Army Communications-Electronics Command, ATTN: DRSEL-ME-MQ, Fort Monmouth, NJ 07703.

In either case, a reply will be furnished direct to you.

**TABLE OF CONTENTS**

SECTION

O	INTRODUCTION	Page
O-1	Scope .....	O-1
O-2	Index of Technical Publications .....	O-1
O-3	Maintenance Forms, Records and Reports .....	O-1
O-4	Reporting Equipment Improvements Recommendations (EIR) .....	O-1
O-5	Administrative Storage .....	O-1
O-6	Destruction of Army Electronics Materiel .....	O-1
O-7	Warranty Information .....	O-1

---

This manual is an authentication of the manufacturer's commercial literature which, through usage, has been found to cover the data required to operate and maintain the equipment. Since the manual was not prepared in accordance with MIL-SPECS and AR 310-3, the format has not been structured to consider levels of maintenance, nor is it structured to the normal style of military publications.

Section	Page	Section	Page
I	INTRODUCTION .....	1-1	
	Description .....	1-1	
	1-2 Basic Frame .....	1-1	
	1-4 Model-Manual Information.....	1-1	
	1-6 Specifications .....	1-1	
	1-8 Options .....	1-1	
	1-9 Metric Calibration (Option 001) .....	1-1	
	1-11 X-Axis Retransmitting Potentiometer (Option 003) .....	1-1	
	1-13 Accessories .....	1-1	
	1-15 Model 7562A Logarithmic Converter .....	1-1	
	1-17 Model 7563A Log Voltmeter/ Amplifier .....	1-4	
	1-19 Model 17108A Time Base .....	1-4	
	1-21 Model 10025A Straight- through Voltage Probe .....	1-4	
	1-23 Model 10111A Adapter .....	1-4	
	1-25 Model 10002A/B/C/D Voltage Divider Probe .....	1-4	
	1-27 Model 11000A Cable Assembly .....	1-4	
	1-29 Typical Performance .....	1-4	
	1-30 Input Resistance vs Off Balance Characteristics .....	1-4	
	1-32 Normal Mode Noise .....	1-4	
	1-34 Dynamic Response.....	1-5	
II	INSPECTION AND INSTALLATION		
	2-1 Introduction .....	2-1	
	2-3 Incoming Inspection .....	2-1	
	2-4 Mechanical Checks .....	2-1	
	2-6 Electrical Checks .....	2-1	
	2-8 Damage Claims .....	2-1	
	2-10 Storage .....	2-1	
	2-12 Shipping .....	2-1	
	2-14 Recorder Installation .....	2-1	
	2-16 Cooling .....	2-1	
	2-18 Stacking H-P Instruments .....	2-1	
III	OPERATING INSTRUCTIONS		
	3-1 Operating Requirements .....	3-1	
	3-2 General .....	3-1	
	3-4 Controls, Connectors, and..... Indicators .....	3-1	
	3-6 Electrical Requirements .....	3-1	
	3-7 Operating Power .....	3-1	
	3-9 Input Signals .....	3-1	
	3-11 Grounding .....	3-1	
	3-13 Recording Input Connections .....	3-1	
	3-15 Connection Techniques for the Guard Shield .....	3-1	
	3-17 Maximum Allowable Source Impedance .....	3-1	
	3-19 Operating Precautions .....	3-3	
	3-23 Operating Instructions .....	3-3	
	3-24 Operational Conditions.....	3-3	
	3-26 Connect Power .....	3-3	
	3-28 Connect Inputs .....	3-3	
	3-30 Energize Recorder .....	3-3	
	3-32 Install Paper .....	3-4	
	3-34 Install Pen .....	3-4	
	3-36 Zero Set .....	3-4	
	3-38 Lower Pen .....	3-4	
IV	THEORY OF OPERATION		
	4-1 General Operation Description .....	4-1	
	4-7 Circuit Description .....	4-1	
V	MAINTENANCE, PERFORMANCE, CHECKS AND ADJUSTMENTS		
	5-1 Introduction .....	5-1	
	5-3 Preventive Maintenance .....	5-1	
	5-4 General .....	5-1	
	5-6 Environmental Operation.....	5-1	
	5-8 Cleaning .....	5-1	
	5-10 Potentiometer Cleaning .....	5-2	
	5-12 Lubrication .....	5-2	
	5-14 Visual Lubrication .....	5-2	
	5-16 Mechanical Maintenance.....	5-2	
	5-17 Disassembly/Assembly .....	5-2	
	5-19 Carriage Arm Removal .....	5-3	
	5-21 Pen Carriage Removal .....	5-3	
	5-23 Potentiometer Replacement - X-Axis .....	5-4	
	5-25 Wiper Replacement - X-Axis .....	5-4	
	5-27 Potentiometer Replacement - Y-Axis .....	5-5	
	5-29 Wiper Replacement - Y-Axis .....	5-5	
	5-31 Servo Motor Maintenance .....	5-5	
	5-33 X-Axis Servo Motor Replacement .....	5-5	
	5-35 Y-Axis Servo Motor Replacement .....	5-5	
	5-37 Brush Replacement .....	5-6	
	5-39 Correction of Sticking Motor Brushes .....	5-6	
	5-41 Y-Axis Restringing .....	5-6	
	5-43 X-Axis Restringing .....	5-6	
	5-45 Electrical Maintenance .....	5-7	
	5-46 Requirements .....	5-7	
	5-48 Performance Tests .....	5-7	
	5-49 Criteria .....	5-7	
	5-51 Test Equipment .....	5-7	
	5-53 Initial Checks.....	5-8	
	5-55 Y-Axis Accuracy and Linearity .....	5-8	
	5-56 X-Axis Accuracy and Linearity .....	5-8	
	5-57 Y-Axis Slewing Speed.....	5-8	
	5-58 X-Axis Slewing Speed.....	5-8	
	5-59 Common Mode Rejection .....	5-9	
	5-60 DC Rejection .....	5-9	
	5-61 AC Rejection .....	5-9	
	5-62 Mechanical Adjustments .....	5-9	
	5-63 Procedure .....	5-9	
	5-65 Y-Axis Drive String Tension Check/Adjustment .....	5-9	

**TABLE OF CONTENTS (CONTINUED)**

Section	Page	Section	Page
5-68 Y Gear Train Backlash Adjustment .....	5-10	6-4 Alphanumerical Table .....	6-1
5-70 Y-Axis Pen Carriage Adjustment .....	5-10	6-6 Miscellaneous Parts .....	6-1
5-72 Y-Axis Alignment .....	5-11	6-8 Recommended Spares .....	6-1
5-74 X-Axis Cable Tension Check/Adjustment .....	5-11	6-10 Code List of Manufacturers .....	6-1
5-77 X-Axis Drive Belt Tension Check/Adjustment .....	5-11	6-12 Illustrated Parts Breakdown.....	6-1
5-80 X-Axis Drive Belt Replacement.....	5-11	VII TROUBLESHOOTING	
5-82 X Gear Train Backlash Adjustment .....	5-13	7-1 Introduction .....	7-1
5-84 X-Axis Track Bearing Adjustment .....	5-13	7-2 Content .....	7-1
5-86 X-Axis Drive Train Bearing Replacement .....	5-13	7-4 Troubleshooting .....	7-1
5-91 Electrical Adjustments.....	5-14	7-5 Requirements.....	7-1
5-92 Gain Adjustment .....	5-14	7-7 Troubleshooting Index.....	7-1
5-94 Calibration Adjustment .....	5-14	VIII BACKDATING	
5-96 Phase Shift Adjustment .....	5-15	8-1 Requirements .....	8-1
VI PARTS LIST		8-2 Definitions .....	8-1
6-1 Introduction .....	6-1	8-4 Change I .....	8-1
6-3 Parts List .....	6-1	8-6 Change II .....	8-3
		8-8 Change III .....	8-3
		8-10 Change IV .....	8-4
		8-12 Change V .....	8-4
		8-14 Change VI .....	8-7
		8-16 Change VII .....	8-7
		APPENDIX A REFERENCES .....	A-1
		B MAINTENANCE ALLOCATION.....	B-1

**LIST OF ILLUSTRATIONS**

Figure		Page	Figure		Page
1-1	Model 7035B X-Y Recorder .....	1-0	5-5	Pen Scale Removal .....	5-4
1-2	Model 7035B X-Y Recorder- Opt. 001 (With Wing Brackets) .....	1-0	5-6	Carriage Arm Removal .....	5-4
1-3	Instrument Identification .....	1-1	5-7	Removal of X-Axis Rebalance Potentiometer .....	5-4
1-4	Dimension Drawing .....	1-3	5-8	X-Axis Wiper Protection .....	5-4
1-5	Accessories .....	1-3	5-9	Servo Motor Maintenance and Backlash Adjustments .....	5-5
1-6	Input Resistance Characteristics .....	1-5	5-10	Nylon Cable (Attachment to Pen Block) .....	5-6
1-7	Typical Frequency Response (Input Filter) .....	1-6	5-11	Restraining Diagram .....	5-7
1-8	Typical Dynamic Response .....	1-6	5-12	Y-Axis Slewing Speed Test Setup.....	5-8
2-1	Wing Bracket Installation .....	2-2	5-13	Slewing Speed Determination.....	5-9
2-2	Stacked Configuration .....	2-2	5-14	X-Axis Slewing Speed Test Setup.....	5-9
3-1	Front Panel Controls (7035B and 7035B-001) Models .....	3-2	5-15	Y-Axis Drive String Tension Check .....	5-10
3-2	Rear Panel .....	3-3	5-16	Y-Axis Backlash Adjustment (Gear Adjusting Screw) .....	5-10
3-3	Disposable Pen Installation .....	3-4	5-17	Y-Axis Backlash Adjustment (Gear Locking Screw) .....	5-10
4-1	Block Diagram .....	4-2	5-18	Y-Axis Pen Carriage Adjustment.....	5-11
4-2	Detailed Block Diagram.....	4-2	5-19	Y-Axis Alignment .....	5-12
4-3	Range Selector .....	4-3	5-20	X-Axis Cable Tension Check .....	5-12
4-4	Input Filter .....	4-3	5-21	X-Axis Drive Belt Tension Check .....	5-12
4-5	Zero Circuit .....	4-3	5-22	Drive Train Adjustments .....	5-13
4-6	Slidewire and Damping Circuit.....	4-3	5-23	X-Axis Gear Train Bearings .....	5-14
4-7	Photochopper and Balance Circuit.....	4-4	5-24	Circuit Board Adjustment .....	5-15
4-8	Differential Amplifier .....	4-4	6-1	Exploded View - Cabinet .....	6-9
4-9	Voltage Amplifier .....	4-5	6-2	Exploded View - Carriage Arm (Sheet 1 of 2) .....	6-10
4-10	Amplifier/Demodulator .....	4-5	6-2	Exploded View - Carriage Arm (Sheet 2 of 2) .....	6-11
4-11	Motor Control and Demodulator .....	4-5	7-1	Component Identification - Frame .....	7- 8
4-12	Power and Reference Supply .....	4-6	7-2	Component Identification - Circuit Board .....	7-9
4-13	Neon Driver. ....	4-6	7-3	Schematic Model 7035B (D-07035-92550) .....	7-10
4-14	Autogrip Power Supply .....	4-6	8-1	Component Identification - Circuit Board .....	8-2
4-15	Pen Drop Supply .....	4-6	8-2	Control Panels - Model S 0735B and 7035B-001 .....	8-3
5-1	Potentiometer Cleaning .....	5-2	8-3	IEC Power Connection .....	8-4
5-2	Potentiometer Lubrication.....	5-2	8-4	Filling Ink Pen .....	8-4
5-3	Tilting Out Entire Circuit Board Assembly.....	5-3	8-5	Exploded View - Carriage Arm .....	8-6
5-4	Side Panel Removal .....	5-3			

**LIST OF TABLES**

Table		Page	Table		Page
1-1	Model 7035B Specifications .....	1-2	6-3	Recommended One Year Isolated Spare Parts List .....	6-7
1-2	Accessory Supplies .....	1-4	6-4	Manufacturer's Code List .....	6-8
5-1	Recommended Test Equipment .....	5-8	7-1	7035B Troubleshooting Index .....	7-2
6-1	Parts List .....	6-2			
6-2	Miscellaneous Parts .....	6-6			

## SECTION O

## INTRODUCTION

**O-1. Scope**

This manual contains the general description, installation, operation, principles of operation, and maintenance of the test instrument, which is known as the Recorder RO-458(V)1/U (HP-7035B).

**O-2. Index of Technical Publications**

Refer to the latest issue of DA Pam 310-4 to determine whether there are new editions, changes, or additional publications pertaining to the equipment.

**O-3. Maintenance Forms, Records and Reports**

*a. Reports of Maintenance and Unsatisfactory Equipment.* Department of the Army forms and procedures used for equipment maintenance will be those prescribed by TM 38-750, The Army Maintenance Management System.

*b. Report of Packaging and Handling Discrepancies.* Fill out and forward SF 364 (Report of Discrepancy (ROD)) as prescribed in AR 735-11-2/DLAR 414.55/NAVMATINST 4355.73/AFR 400.54/MCO 30.3E.

*c. Discrepancy in Shipment Report (DISREP) (SF 361).* Fill out and forward Discrepancy in Shipment Report (DISREP) (SF 361) as prescribed in AR 55-38/NAVSUPINST 4610.33B/AFR 75-18/MCOP4610.19C/DLAR 4500.15.

**O-4. Reporting Equipment Improvement Recommendations (EIR)**

If your Recorder RO-458(V)1/U needs improvement, let us know. Send us an EIR. You, the user, are the only one who can tell us what you don't like about your equipment. Let us know why you don't like the design. Tell us why a procedure is hard to perform. Put it on an SF 368 (Quality Deficiency Report). Mail it to Commander, US Army Communications-Electronics Command, ATTN: DRSEL-ME-MQ, Fort Monmouth, NJ 07703. We'll send you a reply.

**O-5. Administrative Storage**

For administrative storage of your transmission level and return loss measuring set, wrap set in heavy kraft paper and tape securely with packaging tape.

**O-6. Destruction of Army Electronics Materiel**

Destruction of Army electronics materiel to prevent enemy use shall be in accordance with TM 750-244-2.

**O-7. Warranty Information**

The RO-458(V)1/U (Model HP-7035B) X-Y Recorder is warranted by the HEWLETT-PACKARD company for one year from the date of shipment. Warranty period starts on the date found in block 23 of DA Form 2408-9 in the logbook. Report all defects in material or workmanship to your supervisor, who will take appropriate action through your organizational maintenance shop.

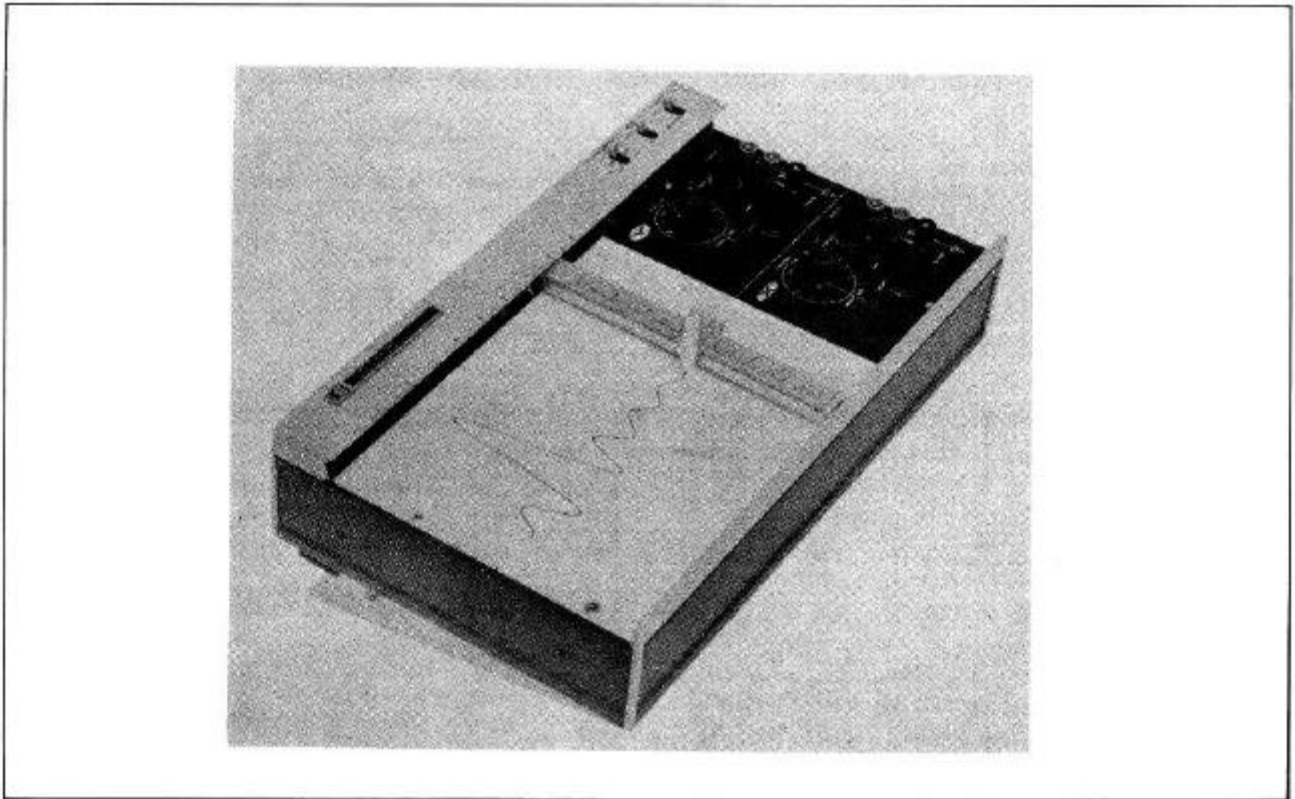

FIGURE 1-1. MODEL 7035B X-Y RECORDER

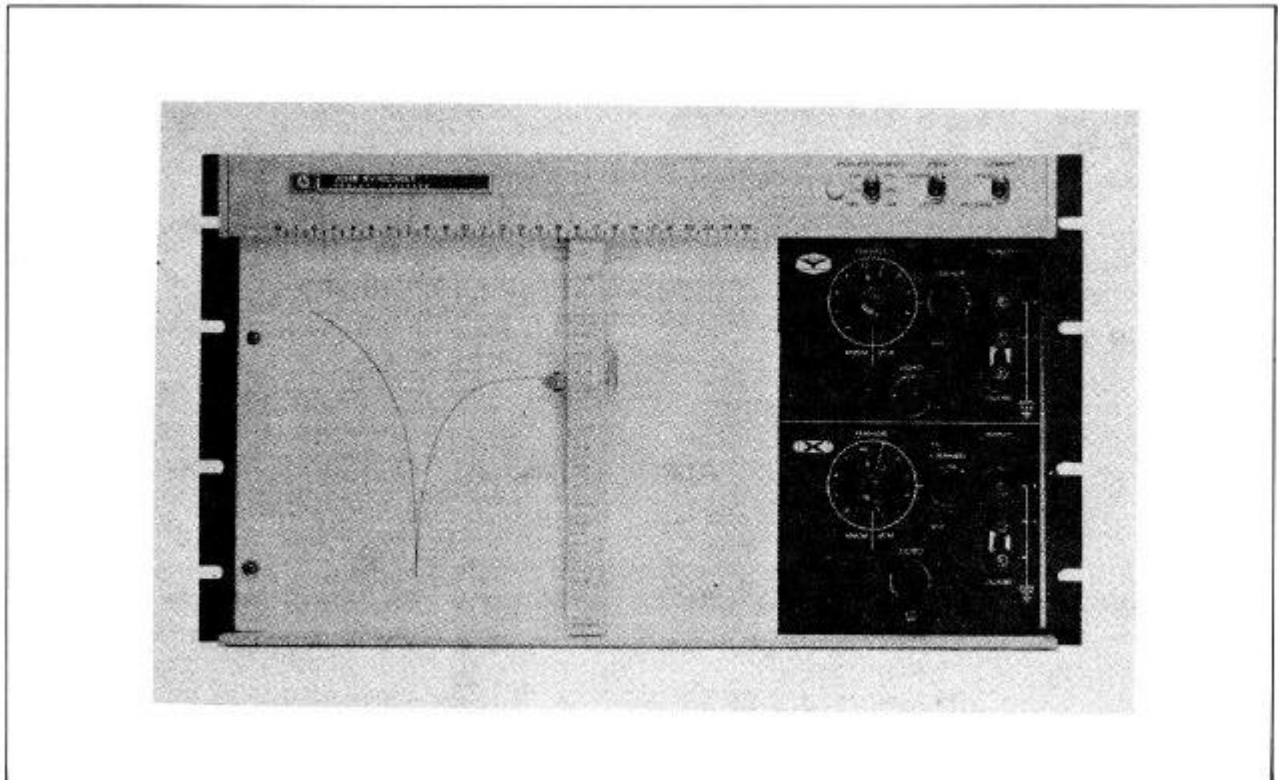

FIGURE 1-2. MODEL 7035B X-Y RECORDER - OPTION 001 (WITH WING BRACKETS)

## SECTION I

### INTRODUCTION

#### 1-1. DESCRIPTION

#### 1-2. BASIC FRAME

1-3. The Hewlett-Packard Model 7035B X-Y Recorder is a general purpose laboratory instrument designed for plotting cartesian coordinate graphs from dc electrical sources. Specially guarded and shielded circuitry provides one megohm input resistance at null on all fixed and variable ranges from 100 mV/in. (40 mV/cm) and above. Five calibrated dc input ranges in each axis, the most sensitive is used potentiometrically, are standard features. Arbitrary full scale voltage ranges may be used with calibrated dc ranges by using a variable input attenuator. The Autogrip holddown platen accepts standard 8-1/2 x 11 inches or smaller graph paper. The instrument is readily adaptable from bench to rack mounting by installing the wing brackets provided. See Figures 1-1 and 1-2 for general configuration.

#### 1-4. MODEL-MANUAL INFORMATION

1-5. This manual is applicable to the Model 7035B with a serial prefix of 1114A. The serial prefix is the first four digits and a letter of a two-part ten-item serial number (0000A-00000) used to identify each Hewlett-Packard instrument (see Figure 1-3). Should any change to this manual be necessary, a new serial prefix will be assigned to the changed model and a change sheet (Manual Change) will be supplied defining the differences between the changed model and the one described within this manual.

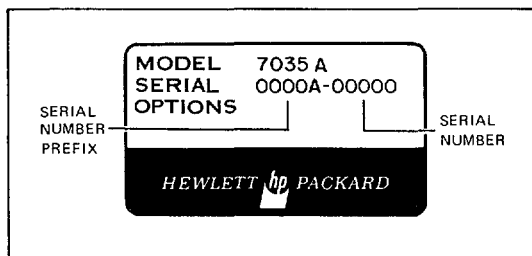

FIGURE 1-3. INSTRUMENT IDENTIFICATION

#### 1-6. SPECIFICATIONS

1-7. Table 1-1 lists the specifications available with this recorder. Figure 1-4 illustrates the outside dimensions.

#### 1-8. OPTIONS

#### 1-9. METRIC CALIBRATION (OPTION 001)

1-10. Ordering this option will provide a metrically scaled and calibrated version of this instrument. (HP Service Center installation only.)

#### 1-11. X-AXIS RETRANSMITTING POTENTIOMETER (OPTION 003)

1-12. This option provides a potentiometer that is coupled to the X-axis drive system. The potentiometer is 5K  $\pm$ 3% with  $\pm$ 0.1% linearity, and 0.04% resolution.

#### 1-13. ACCESSORIES

1-14. Accessories supplied with each instrument depend on the configuration of the instrument, and are listed in Table 1-2. Other accessories for special applications may be ordered. These accessories which do not require modification of the recorder are described in the following paragraphs.

#### 1-15. MODEL 7562A LOGARITHMIC CONVERTER

1-16. The Model 7562A Logarithmic Converter produces dc output voltages in logarithmic relationship to other dc input voltages, or true amplitude RMS of ac input voltages, in a 10,000 to 1 (80 dB) amplitude range. The all solid state, single channel converter allows semilog plotting with X-Y and strip chart recorders. Two converters may be used for log-log records. An oscilloscope output is also provided for waveform monitoring using oscilloscopes. A broad frequency range, 100 kHz to 0.5 Hz, increases its usefulness.



TABLE 1-1. MODEL 7035B SPECIFICATIONS

PERFORMANCE

Input Range: 1, 10, 100 mV/in.; 1 and 10 V/in. (Option 001, Metric calibration: 0.4, 4, 40, 400 mV/cm and 4 V/cm). Continuous vernier between ranges.

Type of Input: Floated and guarded signal pair. Input may be operated up to ±500 Vdc with respect to chassis ground. Signal and guard terminals are available at the front panel or at a rear connector. Mating rear connector supplied.

Input Resistance:

Range	Input Resistance:
1 mV/in. (0.4 mV/cm)	Potentiometric. (essentially infinite at null)
Variable	11k
10 mV/in. (4 mV/cm)	100k
Variable	100k
100 mV/in. (40 mV/cm)	1 meg
Variable	1 meg
1 V/in. (400 mV/cm)	1 meg
Variable	1 meg
10V/in. (4 V/cm)	1 meg
Variable	1 meg

Maximum Allowable Source Resistance: 20k ohm on most sensitive range, no restriction on other ranges.

Normal Mode Rejection (at line frequency): > 30 dB (18 dB/octave roll-off above 60 Hz).

Common Mode Rejection: Conditions for the following data are DC or line frequency AC with up to 1K ohm between the positive input and negative input, and the negative input connected to the guard terminal. Maximum allowable DC or DC plus peak AC common mode voltage is 500V.

Range		DC (CMR)	AC (CMR)
Standard	Metric		
1 mV/in.	0.4 mV/cm	130 dB	100 dB
10 mV/in.	4 mV/cm	110 dB	80 dB
100 mV/in.	40 mV/cm	90 dB	60 dB
1V/in.	400 mV/cm	70 dB	40 dB
10 V/in.	4 V/cm	50 dB	20 dB

Slewing Speed 20 in/s, 50 cm/, nominal at 115V line.

Accuracy: ±0.2% of full scale.

Linearity: ±0.1% of full scale.

Resettability: ±0.1% of full scale

Reference Stability: Continuous electronic zener reference with temperature stability better than 0.002%/degrees C.

Zero Set: Zero may be placed anywhere on the writing area or electrically off scale up to one full scale from zero index. Adjustable by a locking ten-turn, high resolution control.

GENERAL

Writing Mechanism: Servo actuated ink pen.

Writing Area: 7 in. X 10 in. (18 cm X 25 cm).

Paper Holddown: Autogrip electric paper hold-down grips charts 8-1/2 in. X 11 in. or smaller. Special paper is not required.

Pen Lift: Electric pen lift with provision for remote control.

Power: 115 or 230 V ± 10%, 50 to 60 Hz, approximately 45 W.

Weight: Net, 18 lb (8 kg; shipping, 24 lb (10.9 kg)

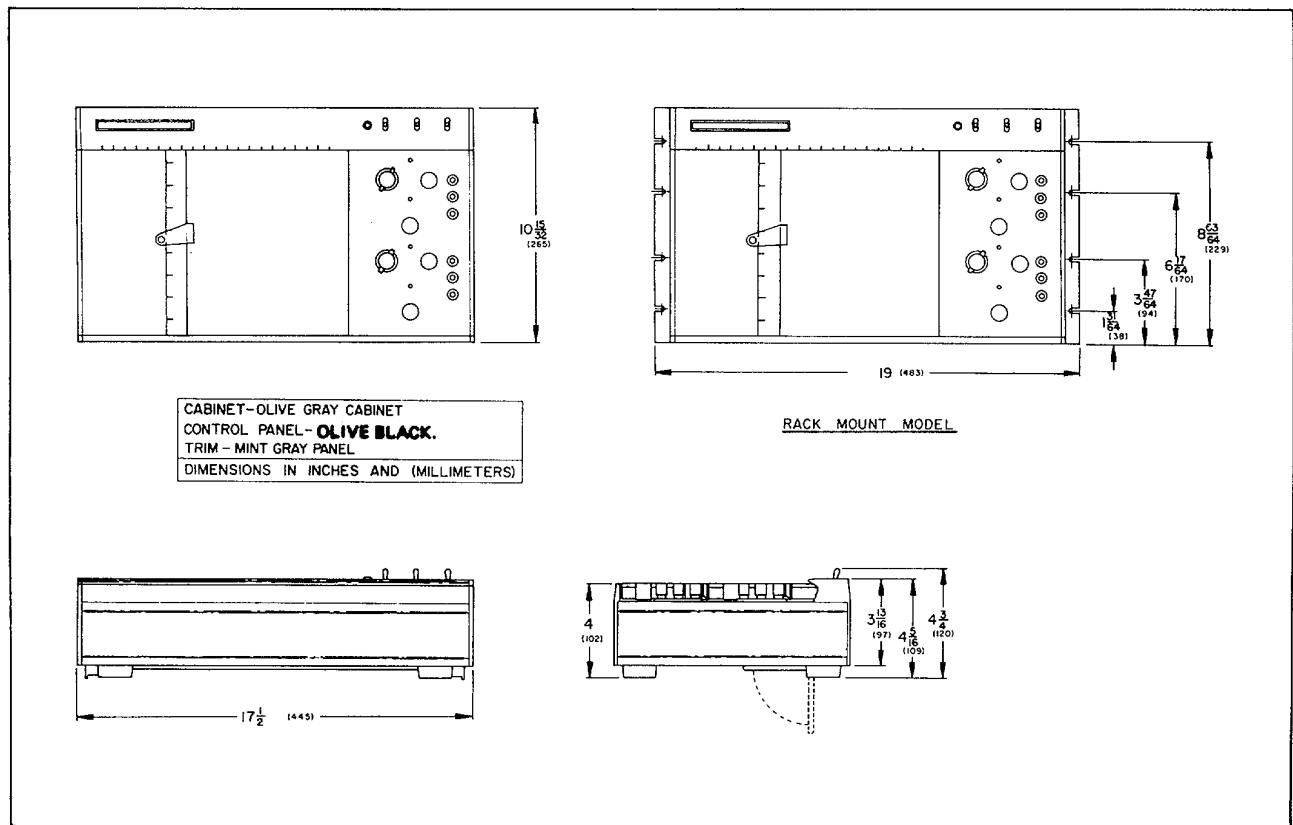

FIGURE 1-4. DIMENSION DRAWING

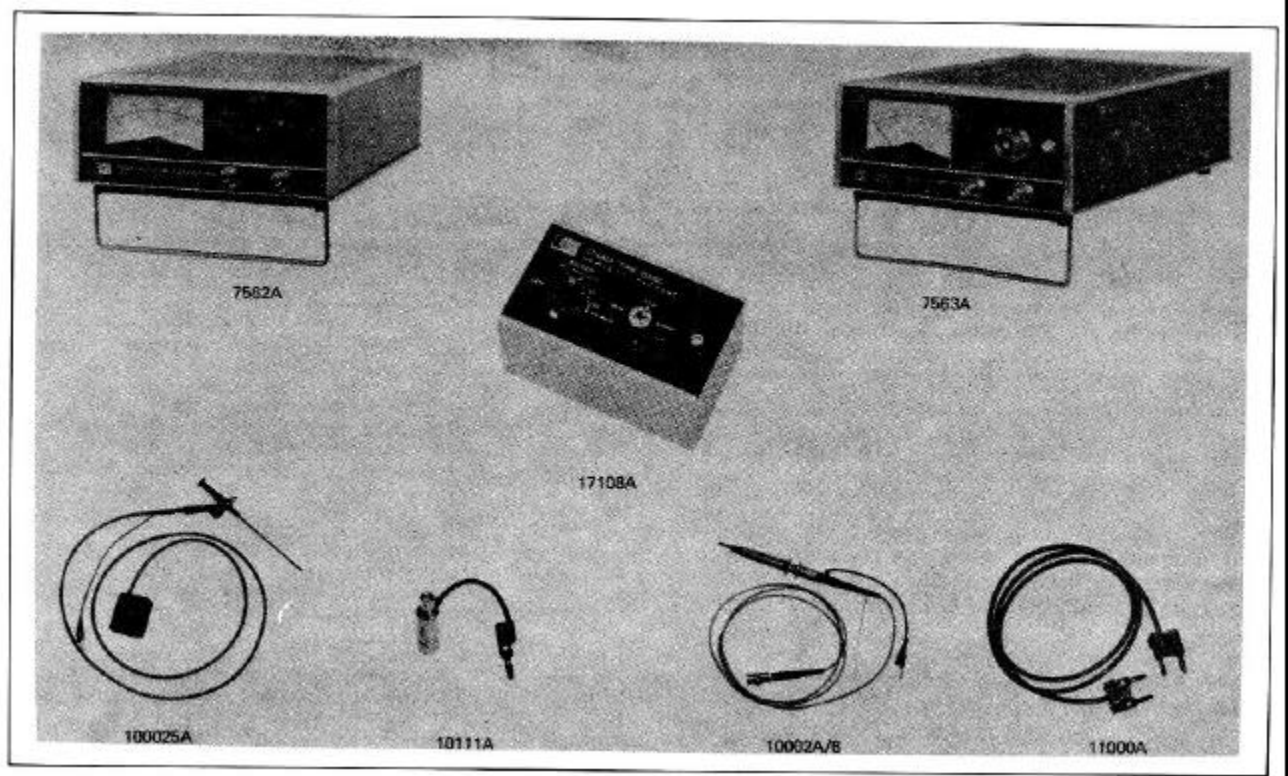

FIGURE 1-5. ACCESSORIES

TABLE 1-2. ACCESSORY SUPPLIES

1251-0293	Connector, Male, 24 pin (Mate to J-602)(1)	2110-0063	Fuse, 3/4 Amp (1)
5080-7979	Pen, Disposable, Red Pack of 3 (1)	2110-0065	Fuse, 3/8 Amp (1)
5080-7980	Pen, Disposable, Blue Pack of 3 (1)	9270-1006	Graph Paper, English Calibrated (Heavy) (10)
1540-0149	Plastic Box (1)	9270-1007	Graph Paper, English Calibrated (Light) (10)
9220-1519	Filler Pad (1)	9270-1023	Graph Paper, Metric Caption-001, Calibrated (Heavy) (10)
5080-3635	Slidewire Lubricant (1)	9270-1027	Graph Paper, Metric Caption-001, Calibrated (Light) (10)
5080-3605	Slidewire Cleaner (1)		
8120-1378	Power Cord (1)		

1-17. MODEL 7563A LOG VOLTMETER/ AMPLIFIER

1-18. The Model 7563A DC Log Voltmeter/Amplifier is designed to perform two independent operations. As a voltmeter, usable over a 110 dB input amplitude range, accurate readings within 1.5 dB over an 80 dB dynamic range are achieved, and the need for range switching is unnecessary. As a log amplifier, output signals are logarithmically related to applied input signals; this solid-state amplifier permits semilogplotting operations with HP X-Y and strip-chart recorders, and will operate with most other recorders and oscilloscopes. Two amplifiers may be used for log-log records.

1-19. MODEL 17108A TIME BASE

1-20. The 17108A is a self-contained external time base which will operate on either axis of the 7035B. Any number of recorders may be driven simultaneously providing the combined parallel input impedance is 20, 000 ohms or more. Five sweep speeds are provided from 0.5 to 50 seconds/inch.

1-21. MODEL 10025A STRAIGHT-THROUGH VOLTAGE PROBE

1-22. The 10025A is a flexible probe with small, pushbutton pincer jaws which provide a straight-through connection to the 7035B. Maximum input voltage is 600 volts peak. The cable is terminated in a shielded dual banana plug.

1-23. MODEL 10111A ADAPTER

1-24. The 10111A (shielded banana-post-to-female-BNC) converts banana post inputs on 7035B to shielded BNC inputs for low-level signal work. This adapter may be used in pairs for balanced input characteristics.

1-25. MODEL 10002A/B/C/D VOLTAGE DIVIDER PROBE.

1-26. The Voltage Divider Probe (50:1) extends the voltage range of the 7035B to 1000 volts full scale. The high input impedance (9 meg of this probe also reduces the loading of the 7035B on the system under test. Accuracy is  $\pm 3\%$ , requires 10111 Adapter, and not usable on the 1 mV/in. and 10 mV/in. (0.4 mV/cm and 4 mV/cm) ranges. The length of the 10002A is 5 feet, 10002B is 10 feet, 10002C is 5 feet with a black identification boot, and the 10002D is 10 feet with a black identification boot.

1-27. MODEL 11000A CABLE ASSEMBLY

1-28. Dual banana plugs terminate a section of 50-ohm cable, 44 inches overall, plugs for binding posts spaced 3/4 inch.

1-29. TYPICAL PERFORMANCE

1-30. INPUT RESISTANCE VS OFF BALANCE CHARACTERISTICS

1-31. The input resistance is constant, regardless of off balance condition except for the 1 mV/in. (0.4 mV/cm) range. This range, operating in potentiometric mode, draws all the current flowing in the balance loop through the input circuit. Referring to Figure 1-6, observe that a linear relationship exists between the distance off balance and the input resistance, and because the input resistance at 1% of full scale off balance is approximately 10 meg ohms, a small off balance condition is noticeable.

1-32. NORMAL MODE NOISE

1-33. This instrument is designed to record dc signals. Normal mode noise (like frequency) is often superimposed on the low frequency, which if not eliminated, may produce unsatisfactory recordings. An excessive amount of noise can

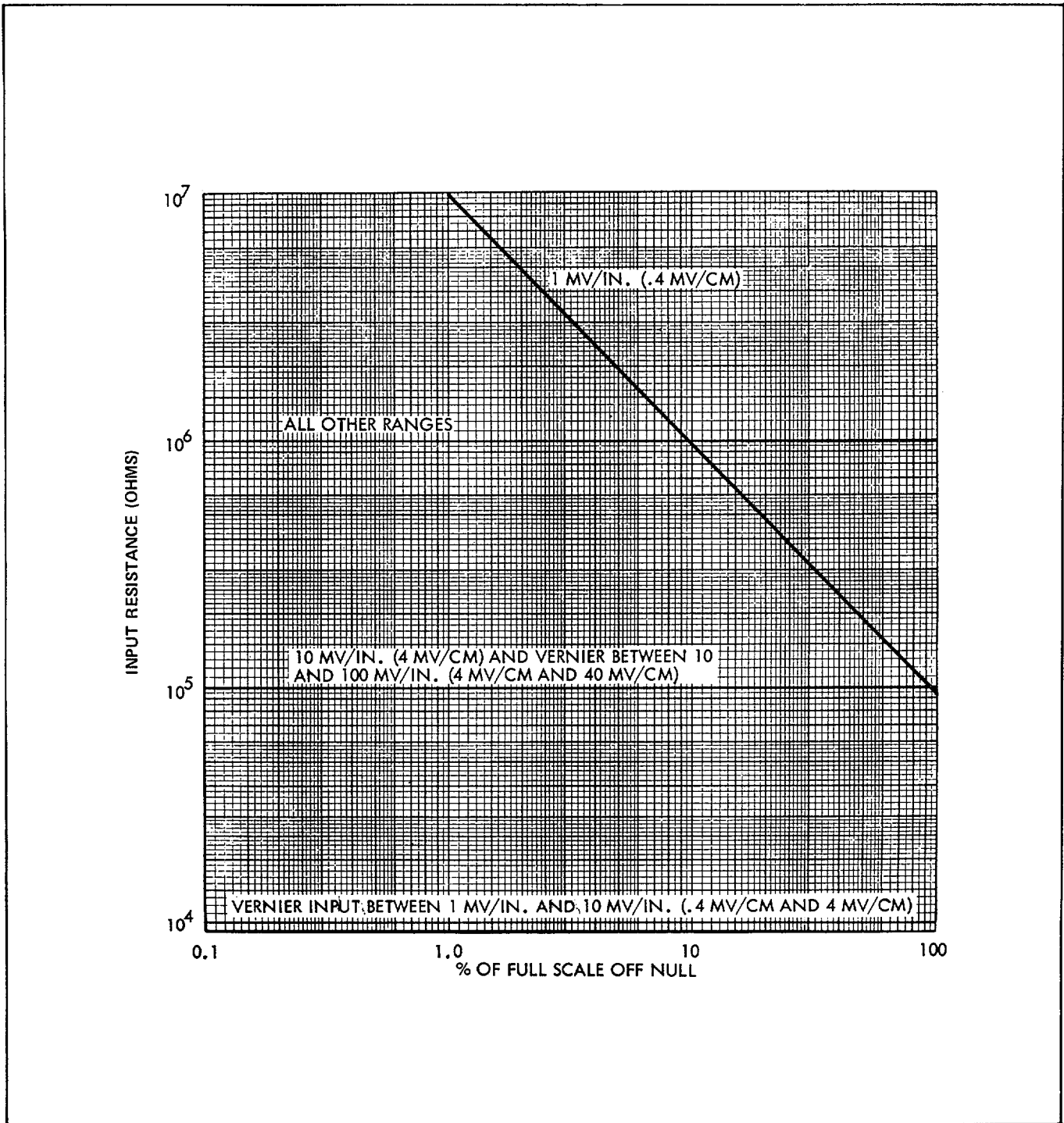

FIGURE 1-6. INPUT RESISTANCE CHARACTERISTICS

saturate the amplifier's output stage causing an increased dead zone and decreased pen speed. Pen oscillation may also result if the noise "beats" with the servo system's carrier frequency. A built-in low pass filter in both axes minimizes the effects of normal mode noise. The response of this filter is illustrated in Figure 1-7.

1-34. DYNAMIC RESPONSE

1-35. Figure 1-8 indicates the typical frequency response for a sinusoidal input. Although the recorder is designed to record slowly varying dc voltages, ac voltages up to a few Hz can be recorded.

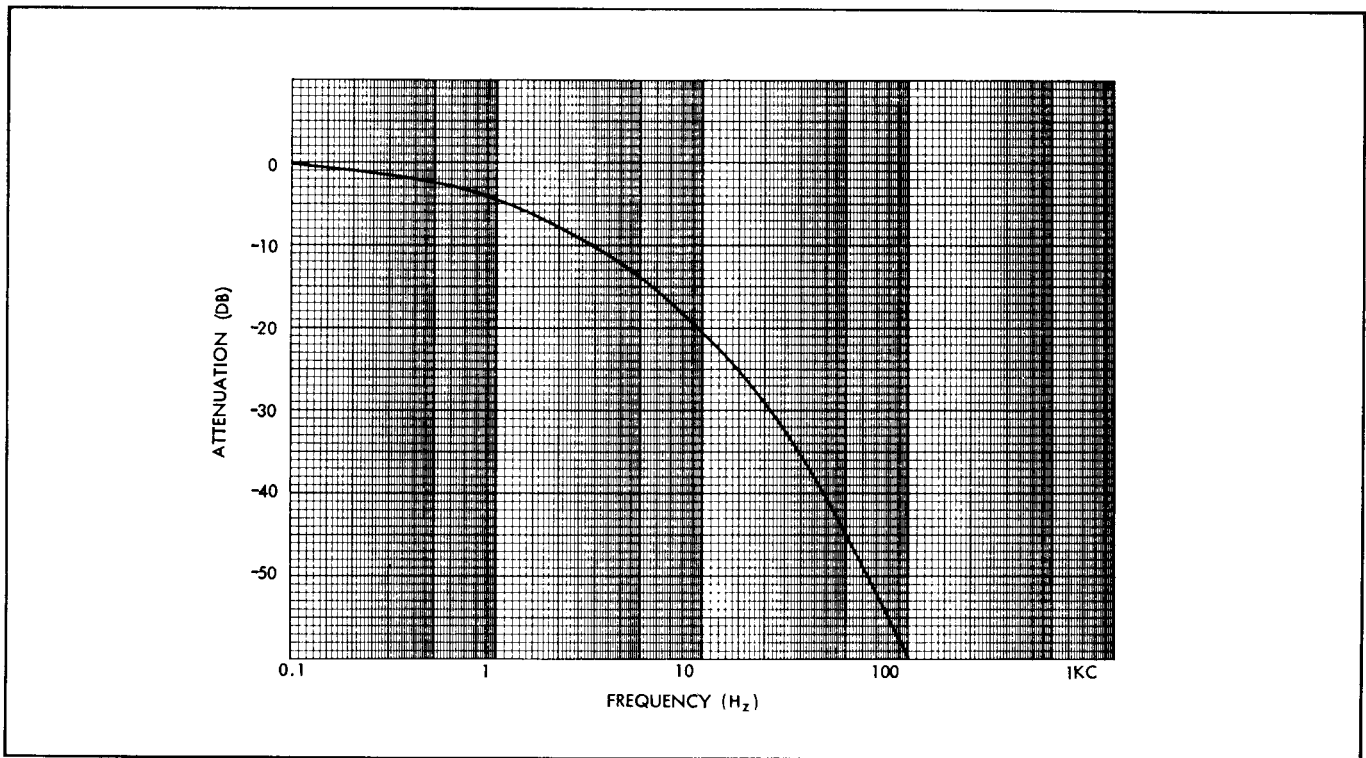

FIGURE 1-7. TYPICAL FREQUENCY RESPONSE (INPUT FILTER)

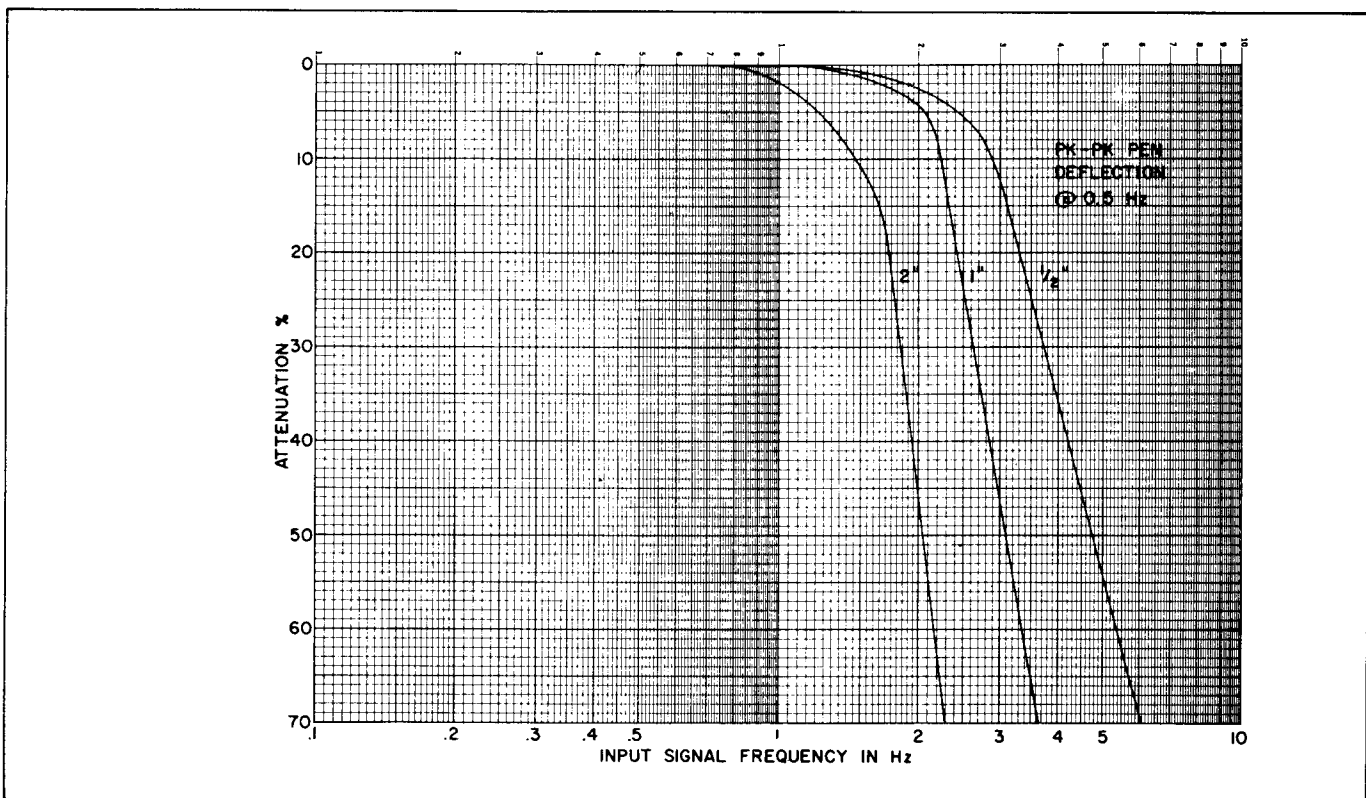

FIGURE 1-8. TYPICAL DYNAMIC RESPONSE

## SECTION II

### INSPECTION AND INSTALLATION

#### 2-1. INTRODUCTION

2-2. This section provides information for incoming inspection, installation, storage, and shipping.

#### 2-3. INCOMING INSPECTION

#### 2-4. MECHANICAL CHECKS

2-5. Inspect the instrument for mechanical damage, scratches, dents, or other defects. Also check the cushioning materials for signs of severe stress.

#### 2-6. ELECTRICAL CHECKS

2-7. The electrical performance of the instrument should be verified upon receipt. Performance checks, suitable for incoming inspection, are presented in Section V.

#### 2-8. DAMAGE CLAIMS

2-9. If the instrument is damaged in transit, or fails to meet specifications upon receipt, follow procedures as outlined in paragraph O-3.

#### 2-10. STORAGE

2-11. If the instrument is to be stored for a period of time, the disposable pen should be removed and the upper part of the carriage arm and pen carriage tied to the side of the instrument to prevent damage during handling. Seal the instrument in a moisture-proof covering and repackage in a container similar to the original factory carton.

#### 2-12. SHIPPING

2-13. The following precautions should be taken when repackaging the recorder:

a. Remove disposable inkpen. Tape a piece of heavy recording paper to Autogrip table surface.

b. Secure upper end of carriage arm and pen carriage to side of recorder to prevent movement while in transit with shipping clamp and pad assembly (Part No. 5080-7834).

c. If recorder is being returned for repair, do not send power cord or accessory kit.

d. Wrap instrument in heavy paper or plastic and surround with three to four inches of shock-absorbing material to cushion and prevent movement inside shipping container. The container should be sufficiently durable to prevent damage to instrument during handling.

#### 2-14. RECORDER INSTALLATION

2-15. This recorder requires no physical installation for table top operation. The accessory wing brackets provided allow installation on standard 19-inch rack console if desired. To install, refer to Figure 2-1.

#### 2-16. COOLING

2-17. Cooling is provided by convection. The location or mounting of the instrument must ensure adequate air circulation.

#### 2-18. STACKING H-P INSTRUMENTS

2-19. The 7035B is equipped with special feet which allow it to be stacked on other H-P instruments. Figure 2-2 shows the 7035B stacked on a 7560A and a 3300A. The rear tilt stand provides easy viewing of the chart.

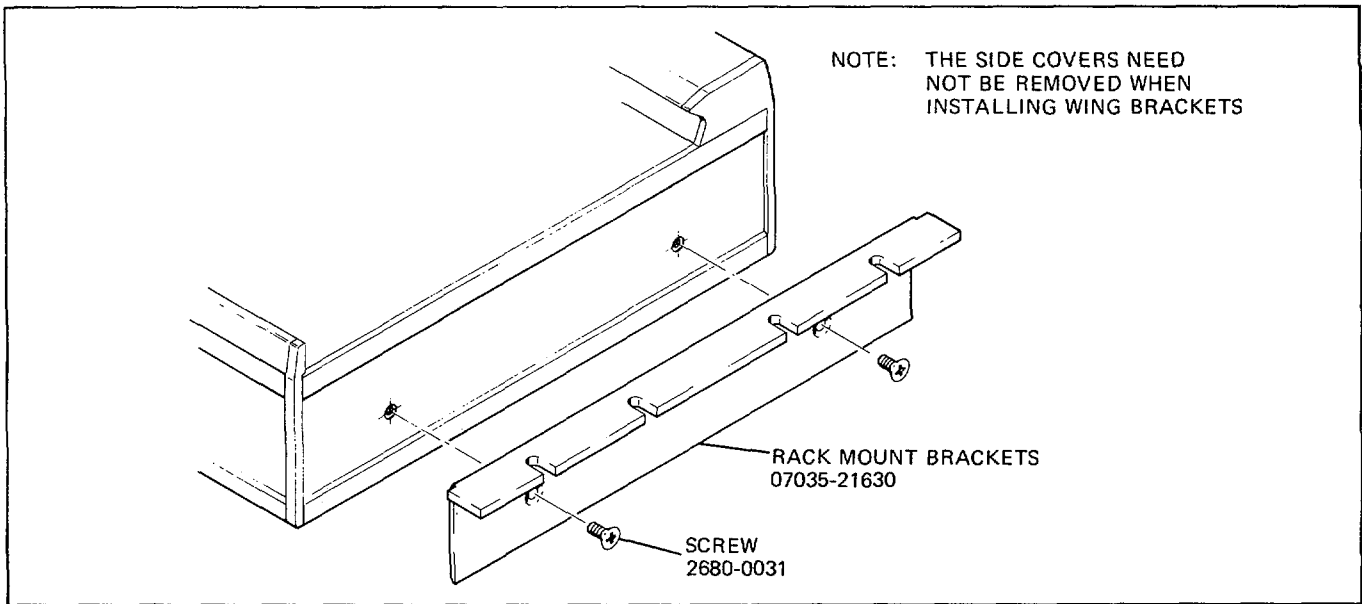

FIGURE 2-1. WING BRACKET INSTALLATION

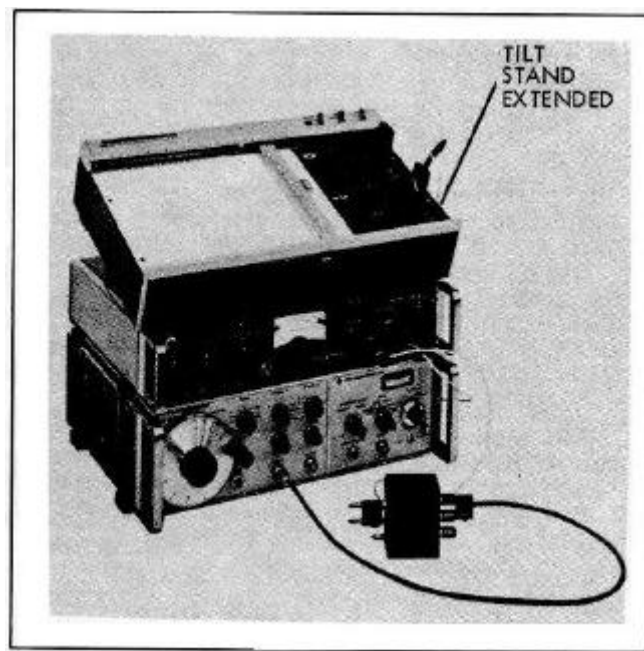

FIGURE 2-2. STACKED CONFIGURATION

## SECTION III

## OPERATING INSTRUCTIONS

## 3-1. OPERATING REQUIREMENTS

## 3-2. GENERAL

3-3. The basic function of the Model 7035B Recorder is to produce graphic tracings showing the relationship between two variable functions. Slowly varying dc signals representing these functions are applied to the input terminals of the respective axes of the instrument, and its controls adjusted so that the resulting graph will cover the desired scope of operation.

**CAUTION** Before attempting to operate this instrument the user should study the following paragraphs.

## 3-4. CONTROLS, CONNECTORS, AND INDICATORS

3-5. The front and rear panel controls, connectors, and indicators are depicted and explained in Figures 3-1 and 3-2.

## 3-6. ELECTRICAL REQUIREMENTS

## 3-7. OPERATING POWER

3-8. The line power supplied to the recorder should be either 115 or 230 volts 10%, 50 to 60 Hz, single phase. A voltage conversion switch, see Figure 3-2, must be set to correspond to the available supply voltage. For 115 Vac use a 3/4 amp fuse. For 230 Vac use a 3/8 amp fuse.

## 3-9. INPUT SIGNALS

3-10. The recorder input terminals (+ and -) must be supplied with a dc signal on each axis. This signal should be in direct proportion to the actual function unless a special relationship is required, such as the logarithmic value of the input voltage. These signals must vary at a rate within the response capabilities of the instrument and have amplitudes within its scale ranges. If an excessive amount of ac noise is present in the input signals, the response of the recorder may become sluggish and erratic or oscillatory.

**CAUTION** Do not directly apply signals in excess of 250 volts on the X-axis or 175 volts on the Y-axis.

## 3-11. GROUNDING

3-12. For optimum performance, the third prong of the ac power cord must be grounded. When operating from ungrounded power sources, adequate grounding is mandatory.

## 3-13. RECORDING INPUT CONNECTIONS

3-14. Input terminals for each axis are located on the front panel adjacent to the corresponding range switches. Front panel terminals will accept either "banana" plugs or open wires.

## 3-15. CONNECTION TECHNIQUES FOR THE GUARD SHIELD

3-16. Connect the recorder's guard shield in one of the following ways:

- a. To the SOURCE ground when:
  1. Operating on low level ranges
  2. When ac noise pickup is a problem.

b. To the negative input using the convenient shorting straps when conditions 1 and 2 do not exist.

**CAUTION** Do not leave the guard shield disconnected or floating. Tighten guard strap securely.

## 3-17. MAXIMUM ALLOWABLE SOURCE IMPEDANCE

3-18. No restrictions except on fixed 1mv/in. (0.4 mv/cm) range. Up to 20k ohm source impedance will not appreciably alter the recorder's performance. Higher source impedance will cause an increase in dead zone and a decrease in pen speed. Values up to approximately 100k may be compensated for by adjusting the servo amplifier gain adjustment (front panel).



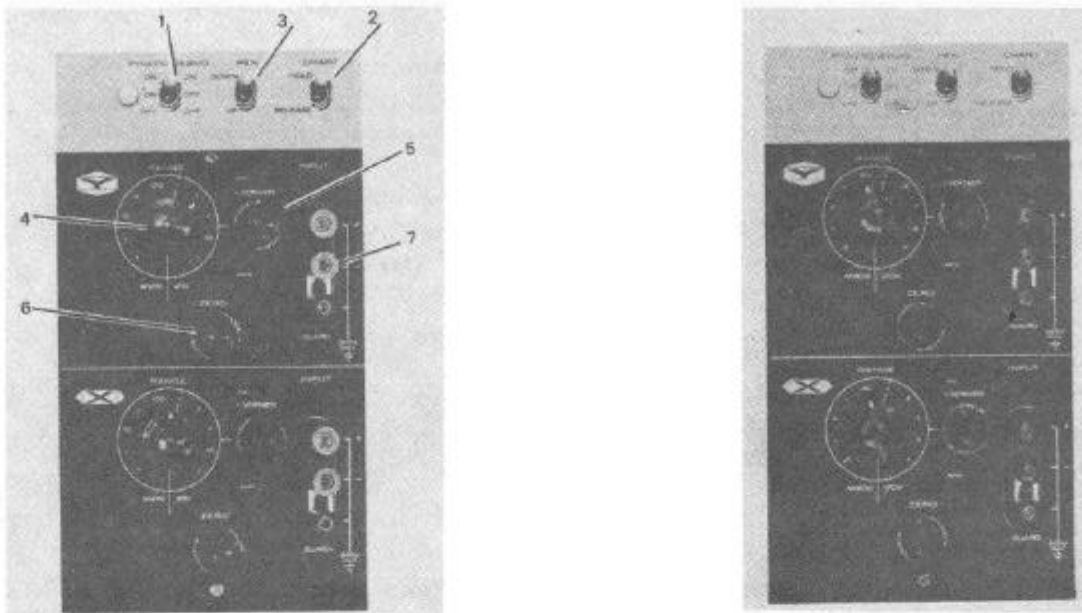

**1. POWER SERVO SWITCH.** A three-position toggle switch, at the upper right of the control panel, controls all recorder power in the following positions:

- a. **OFF-OFF.** Power to the recorder is shut off.
- b. **ON-OFF.** All the circuits in the recorder are operable except for the servo system. This position may be used as Standby.
- c. **ON-ON.** All the circuits in the recorder are operable.

**2. CHART SWITCH.** The Chart Switch controls the Autogrip paper holddown, and the **RELEASE** position de-energizes it.

**3. PEN SWITCH.** The Model 7035B is equipped with an electric pen lift that is controlled by a two-position toggle switch located in the upper right hand section of the instrument.

**4. RANGE SELECTOR.** The range selector is located in the center portion of the control panel, one for each axis. The selector has 5 calibrated positions and 5 uncalibrated positions. Each uncalibrated position is indicated by a small circle. The sensitivity of the uncalibrated position is controlled by the vernier control and can be adjusted to cover the span between the adjacent calibrated ranges.

**CAUTION** Voltage applied between the input terminals should never exceed 175 volts on the Y-axis or 250 volts on the X-axis. No input terminal should be placed more than 500 vdc above the chassis potential.

**5. RANGE SELECTOR VERNIER.** The range vernier is located to the immediate right of the range selector. It is a multi-turn, high resolution potentiometer assembly which adjusts the sensitivity of the recorder when the range selector is in an uncalibrated position.

**6. ZERO CONTROL.** The zero control is located directly below the range selector on the control panel. It is a multi-turn, high resolution potentiometer assembly which controls the zero position of the pen.

**CAUTION** To prevent strain on the servo drives, the zero scale offset should be employed only to counteract a steady-state input which drives the pen toward full scale, or to reposition the minimum point at scale zero. It should not be used to establish the minimum point effectively off the paper, as this will cause the servo drives to exert continuous force against the stop mechanisms and cause excessive clutch wear.

**7. INPUT TERMINALS.** Three input terminals for each axis are located on the right-hand edge of the control panel. Two terminals are polarized and the third is a guard input terminal. Flexible operation is afforded by use of a removable shorting strap between the negative input terminal and the guard. The terminals will accept either open wire or banana plug connectors.

FIGURE 3-1. FRONT PANEL CONTROLS (7035B AND 7035B-001 MODELS)

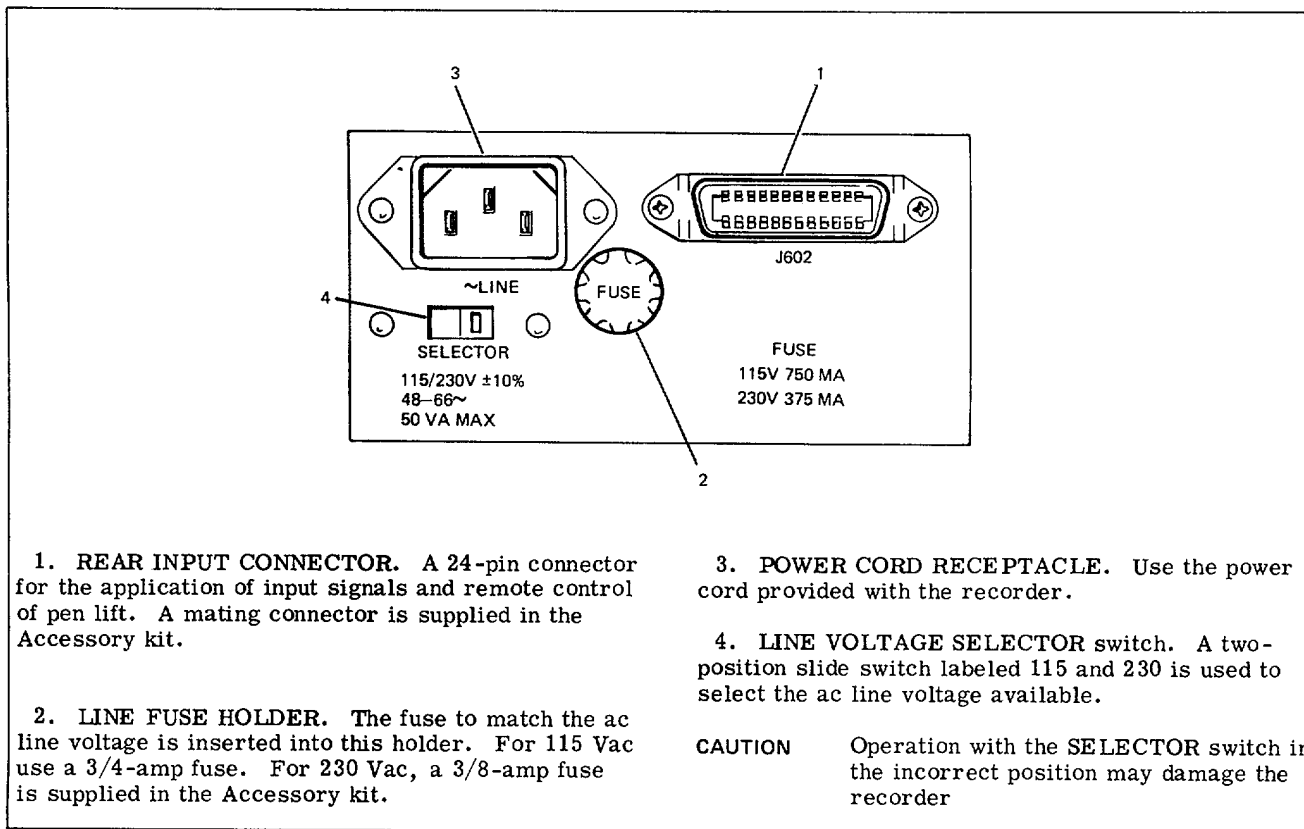

FIGURE 3-2. REAR PANEL

**3-19. OPERATING PRECAUTIONS**

3-20. The POWER/SERVO toggle switch applies 115 volts AC to the recorder. To lower power dissipation and avoid unnecessary wear to the balancing potentiometers and other mechanical parts when not actually recording, place the toggle switch to ON-OFF position.

3-21. When a voltage in excess of the RANGE SETTING is applied to either set of input terminals, the carriage arm or pen mount (depending upon the axis used) will be driven rapidly to full scale and strike the stop. If this condition prevails, the motor will continue running due to a slip-clutch arrangement, prolonged running against the stop may cause excessive motor heating and clutch wear.

3-22. Operation on the most sensitive input range with no input (input terminals not connected) will result in an inaccurate zero null. This can be overcome by shunting the input terminals with a 20k (maximum resistor).

**3-23. OPERATING INSTRUCTIONS**

**3-24. OPERATIONAL CONDITIONS**

3-25. Amplitude of the signal must be within the scale range and vary in level within the response capabilities of the instrument.

**3-26. CONNECT POWER**

3-27. Set the power voltage selector switch located on rear of instrument to either 115 or 230 volts, depending on the available power source. Connect power cord between the power receptacle and the power source.

**3-28. CONNECT INPUTS**

3-29. Connect the signal inputs to each axis through the front input terminals using open wires or banana connectors, or through the rear input connectors using the furnished mating connector. Normally connect the guard input terminal to the negative input terminal. However, if the shields are to be driven directly from a remote common mode source, the jumper is disconnected and a separate wire is connected between the guard input and the common mode voltage source. Set RANGE switch to the expected maximum values.

**3-30. ENERGIZE RECORDER**

3-31. Set the POWER/SERVO toggle switch to ON-ON.

**CAUTION** Units using photochoppers require a few minutes of operation to eliminate dark storage effects. After prolonged storage of 3 to 6 months, a longer period of run in may be required. After several days of storage, a slight improvement in retrace characteristics may be produced by several high speed full scale excursions on each axis.

**3-32. INSTALL PAPER**

3-33. Install a sheet of graph paper on the recording platen, aligning lower and left edges with corresponding paper guides. Set the CHART switch to HOLD, thereby activating the AUTOGRIP holddown system. Smooth paper as necessary.

**3-34. INSTALL PEN**

3-35. The disposable pen is pushed into the notched holder located on the scale, and twisted clockwise to lock in holder. See Figure 3-3.

**CAUTION** The disposable pen incorporates a precision writing tip. Care must be taken not to damage this tip during pen changing or other handling. Writing by hand on any surface may damage pen tip. Use pen only in pen holder on recorder.

**3-36. ZERO SET**

3-37. Connect the input signals to the recorder and adjust ZERO controls so that the resulting graph will cover the desired area on the paper.

**3-38. LOWER PEN**

3-39. Place PEN toggle switch to DOWN position.

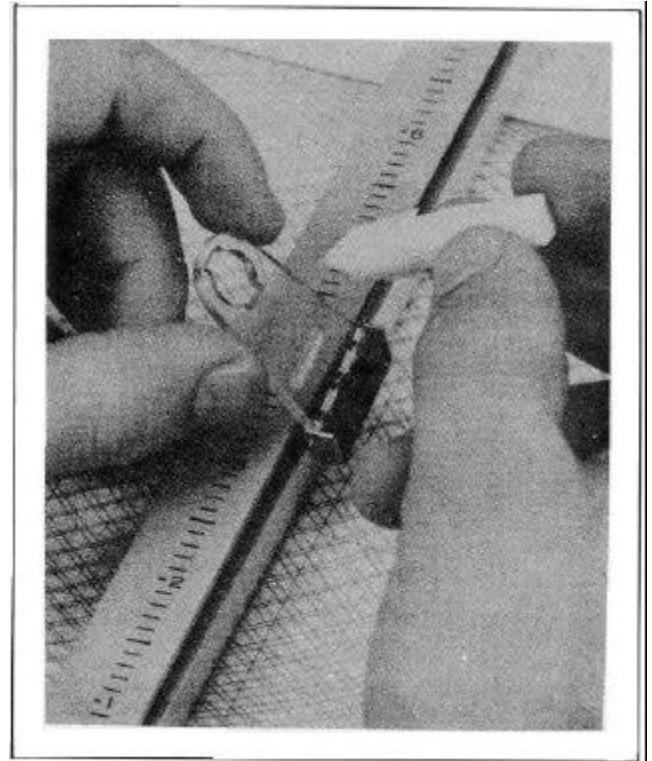

FIGURE 3-3. DISPOSABLE PEN INSTALLATION

## SECTION IV

## THEORY OF OPERATION

**4-1. GENERAL OPERATION DESCRIPTION**

4-2. GUARDED INPUTS. The Model 7035B is equipped with guarded inputs to enable high common mode rejection of 100 db for ac and 130 db for dc voltages. A guard shield encloses the critical input circuitry except for the balance potentiometer which is shielded individually from external coupling. The guard shields are connected to the guard terminals.

4-3. SERVOMECHANISM. There are two similar, but independent, self-balancing servomechanisms in the 7035B, both isolated from ground. In operation, one servomechanism moves the pen carriage in a vertical direction, the other moves the entire carriage arm in a horizontal direction in response to input signals representing data applied to the respective input terminals. The resulting relative motions of the two servomechanisms trace cartesian coordinate graphs of the relationship on the graph paper.

4-4. FIXED AND VERNIER RANGE OPERATION. The basic dc voltage range of the servo systems is 1 millivolt per inch (0.4 mv/cm). Operation with greater voltages is obtained by switching precision resistors into the attenuator circuits. Each range step may be made continuously variable by switching in a variable potentiometer. Adjustment of this control will allow an arbitrary voltage to drive the pen to full scale. In operation, the initial range setting is based on the expected maximum voltages.

4-5. BALANCING ACTION. After passing through the attenuator, the input signal is applied to the balance circuit where it is cancelled by an internally supplied opposing voltage. Under "balanced" conditions, there is no error signal output from the balance circuit and the servo system is at null. When the input signal changes value, an unbalanced condition exists. The resulting error signal is applied to a photochopper which converts the dc to a 60 Hz ac form which is amplified and applied to the servomotor. Because the motor and rebalance potentiometer are mechanically coupled, the balance voltage changes value until the input signal is cancelled. If the input data is constantly varying at rates within

the capabilities of the instrument, this rebalancing action is continuous, and the rebalance potentiometers and the pens are always in a position directly proportional to the amplitude of the signals at the respective input terminals.

4-6. AUTOGRIP HOLDDOWN. The AUTOGRIP holddown platen is completely electronic. There are no mechanical or moving parts. The unit is maintenance free, except for periodic cleaning of the writing surface.

**4-7. CIRCUIT DESCRIPTION**

4-8. Schematic symbols refer to the Y-axis unless otherwise stipulated; however, the X-axis is electrically identical to the Y-axis (with exceptions noted). Reference should be made to the block diagrams, Figures 4-1 and 4-2, and also the schematics referenced in each of the following paragraphs.

4-9. RANGE SELECTOR CIRCUIT (See Figure 4-3). Input terminals of each axis connect to a precision step attenuator which determines the maximum allowable input voltage. The resistors forming the attenuator are R-101 through R-105. The attenuator consists of five precision ( $\pm 0.1\%$ ) metal film resistors with good temperature stability. With the selector switch in the 1 mv/inch (0.4 mv/cm) position, the input voltage is applied directly to the balance circuit with no attenuation. The attenuator is also disconnected as a shunt from the input terminals allowing potentiometric operation in this position. This provides essentially infinite input impedance when the recorder is at null. Typical input currents at null on this range are approximately  $10^{-10}$  amps. The full scale balance voltage is always 7 mv for the Y-axis and 10 mv for the X-axis. For higher ranges, resistance is inserted in series with the 10,000 ohms (R-109) at the base of the attenuator. On the 1 volt/inch (0.4 mv/cm) position, and above, the 10,000 ohms is shunted and no additional series resistance is added.

4-10. RANGE SELECTOR VERNIER CIRCUIT (See Figure 4-3). The 10 position Range selector has 5 calibrated positions and 5 positions that provide a vernier sensitivity that can be adjusted by the user.

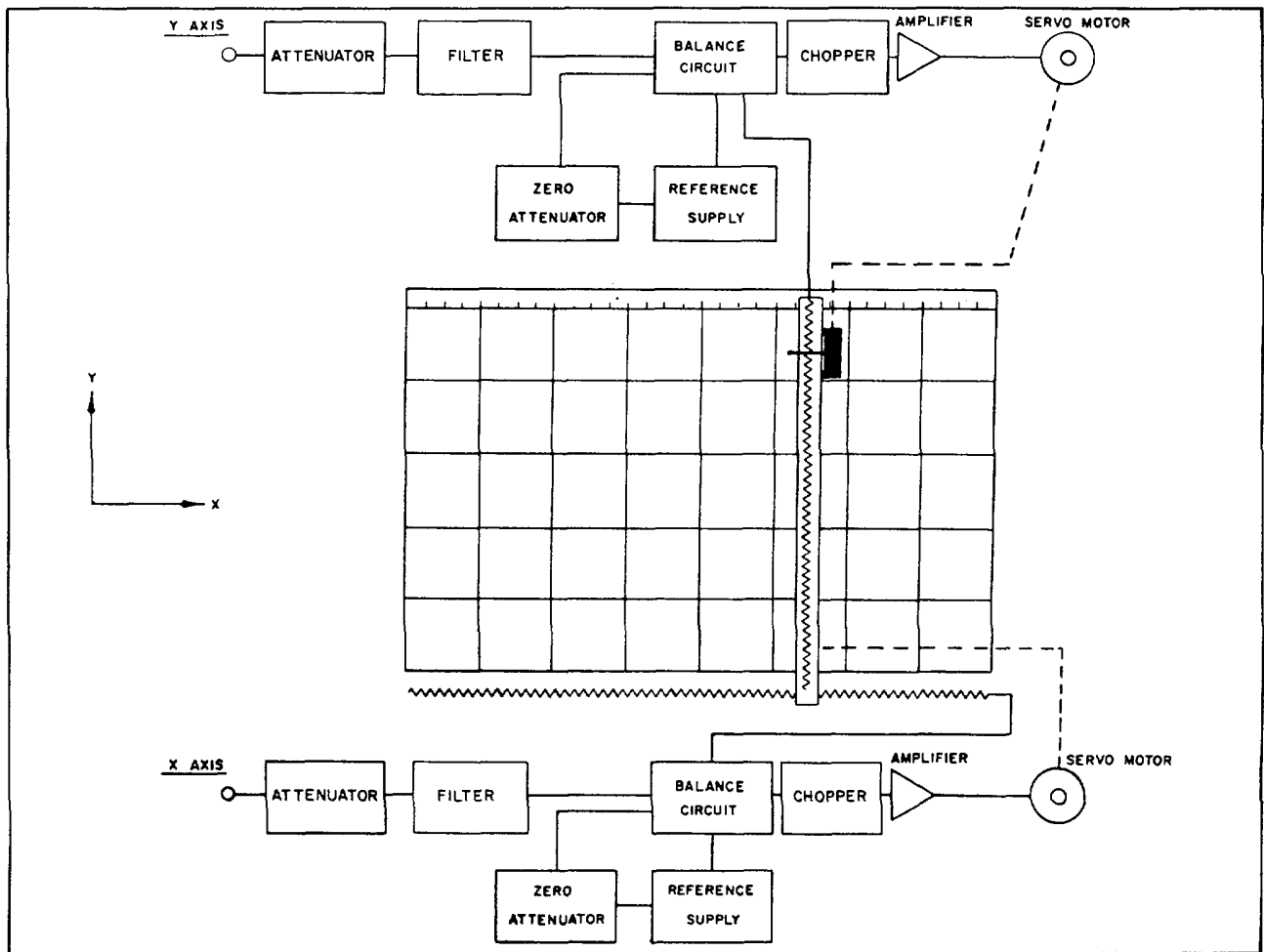

FIGURE 4-1. BLOCK DIAGRAM

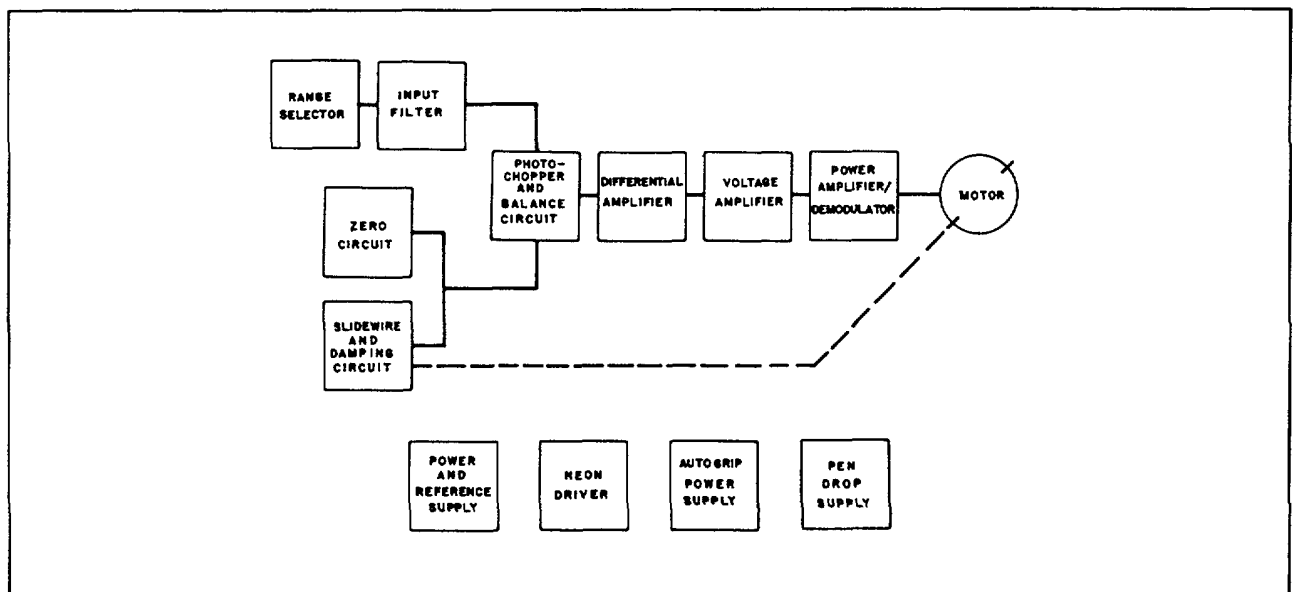

FIGURE 4-2. DETAILED BLOCK DIAGRAM

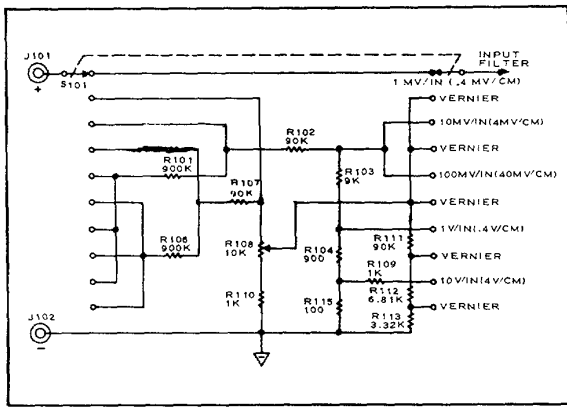

FIGURE 4-3. RANGE SELECTOR

When the Range selector is set to any of the vernier positions the resistors used in the fixed positions are switched out and replaced by a new set of components. The heart of the vernier circuitry is the variable potentiometer R-108 and the voltage limiter R-110. When the range selector is set to the first vernier range, the input signal is applied directly to R-108 and R-110, and passed through the wiper to the balance circuit. The other four positions use R-107 or R-106 to attenuate the signal. In the last two positions the signal from the wiper of R-108 is divided by the string composed of R-111, R-112, and R-113.

4-11. INPUT FILTER (See Figure 4-4.) The input filter is composed of 3 RC sections. It is a low pass filter providing a minimum of 20 db attenuation of 60 Hz and a cutoff of 18 db per octave above 60 Hz to insure smooth plotting from signals containing extraneous noise. Filter components in the Y axis are capacitors C-103, C-104, and C-105, with resistors R-114, R-115, and R-116. The insertion of a filter of this type in each axis of a two-axis recorder can cause phase shift relative to the other axis. Since this phase shift can vary from unit to unit (depending upon component tolerances). R-114 is a variable resistor that is factory adjusted to equalize the phase shift between axes. A slight phase shift, however, will be noted when changing from range to range and when using the range selector vernier. This phase shift may become very pronounced on the 1 mv/inch (0.4 mv/cm) range if the input source impedance is extremely large or extremely small. Diodes CR-101 and CR-102 are protective devices used to minimize the possibility of component damage due to an over-voltage at the input terminals.

4-12. ZERO CIRCUIT (See Figure 4-5.) The zero circuit is composed of R-123 and R-120. The potentiometer R-123 permits the electrical zero to be placed  $\pm 1$  full scale from normal zero. Resistor R-120 limits the voltage that is applied to the Photochopper and Balance Circuit.

4-13. SLIDEWIRE CIRCUIT (See Figure 4-6.) The Slidewire Circuit provides the electrical feedback to the Photochopper and Balance Circuit from the pen carriage or carriage arm. Resistors R-126 and R-125 are calibration resistors for the feedback element (slidewire) R-124. Capacitor C-108 passes unwanted spurious wiper noise to circuit common. Resistor R-121 limits the voltage applied to the Photochopper and Balance Circuit.

4-14. DAMPING NETWORK (See Figure 4-6). The phase lead network (C-107 and R-122) draws a charging current

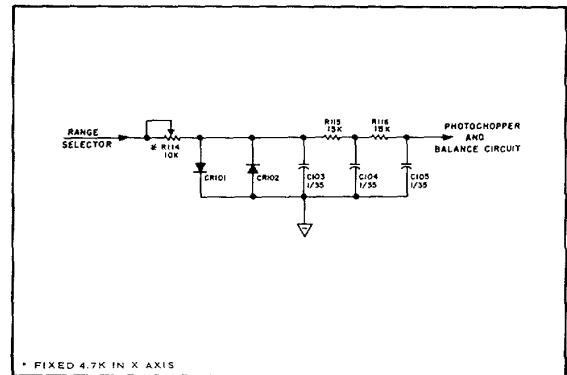

FIGURE 4-4. INPUT FILTER

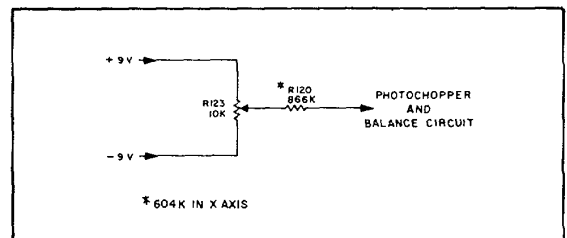

FIGURE 4-5. ZERO CIRCUIT

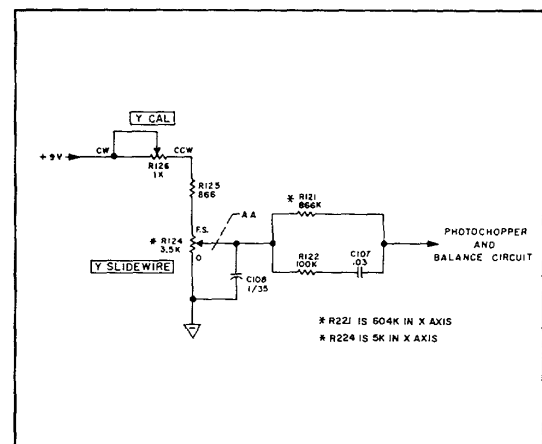

FIGURE 4-6. SLIDEWIRE AND DAMPING CIRCUIT

whenever a change in output occurs, thus increasing the rate of appearance of the balance voltage. This phase advance in the slowly varying error signal causes an "anticipatory" approach to the balance point, producing damping.

4-15. PHOTOCHOPPER AND BALANCE CIRCUIT (See Figure 4-7). The Photochopper and Balance Circuit algebraically sums the outputs of the Input Filter, Zero Circuit, and Slidewire and Damping Network, and converts the summation to 50 or 60 Hz form depending on the power line frequency. Resistor R-119 sums the outputs from the Zero Circuit and Slidewire and Damping Network. C-106 suppresses spurious voltages that may appear across R-119. The voltage difference between the potential across R-119 and the potential from the Input Filter is applied across the photoconductive cells and their load resistors R-117 and R-118. The photoconductive cells V-101 and V-102 are alternately turned on and off by neon bulbs DS-2 and DS-4. The bulbs are driven as described in Paragraph 4-22 in synchronism with the power line. This switching action of the photoconductive cells causes an ac error signal output whose peak-to-peak amplitude is equal to the dc error signal. The ac error signal will be either in phase or 180 degrees out of phase, with respect to the power line, depending on the polarity of the dc error signal. The direction of rotation of the servo motor is determined by the relative phase excitation of the winding in the servo amplifier's output Power Amplifier/Demodulator Stage and the phase of the ac error signal. This phase sensing causes the motor to drive potentiometer R-174 in a direction necessary to seek balance. The total magnitude of the error signal never exceeds 10 mv on the X-axis or 7 mv on the Y-axis, and as the instruments must be sensitive to approximately 0.1% of this voltage, it is apparent that error signals present are exceedingly small, actually in the low microvolt region. With this in mind, all input circuitry is carefully engineered to minimize interference from stray hum pickup and thermal emfs.

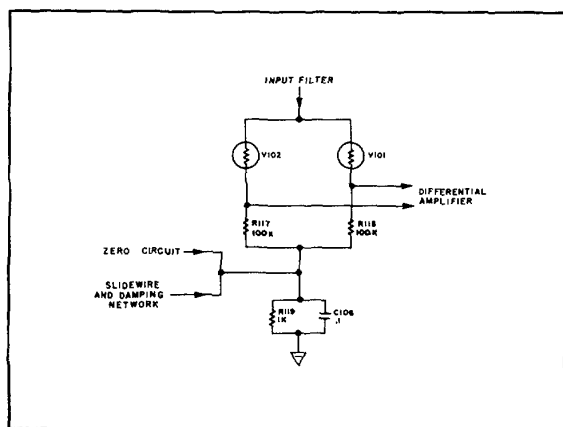

FIGURE 4-7. PHOTOCHOPPER AND BALANCE CIRCUIT

4-16. DIFFERENTIAL AMPLIFIER (See Figure 4-8). The ac error signal from the Modulator and Balance Network is applied to the Gates of Q-101 and Q-102 through coupling capacitors C-109 and C-110. At time  $T_1$ ; a positive voltage is applied to the Gate of Q-101, the Source will follow the Gate, and a positive voltage appears at the Source of Q-102. This positive voltage at the Source, together with the negative voltage at the Gate, causes Q-102 to "shut-off" and the Drain becomes more positive. At time  $T_2$ , the Source-Gate junction of Q-102 to turn on and the Drain will become more negative. Components R-130, C-115, R-129, and C-114 are power supply filters. Capacitors C-112 and C-113 couple the signal from Q-101 to Q-102. Resistors R-128 and R-132 provide Source loads, and R-131 provides the Drain load for Q-102. This stage has a voltage gain of approximately ten.

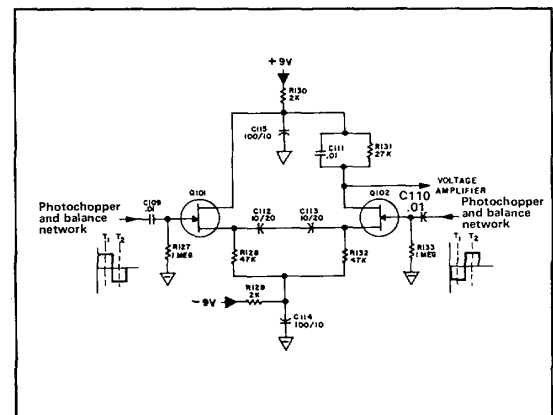

FIGURE 4-8. DIFFERENTIAL AMPLIFIER

4-17. VOLTAGE AMPLIFIER (See Figure 4-9.) The ac error signal from the Differential Amplifier is capacitor coupled by C-116 to the base of the first transistor in the voltage amplifier, Q-103. This high voltage gain section is comprised of three dc coupled silicon transistors, Q-103, Q-104, and Q-105. This stage has a minimum ac feedback of 20 db to insure stable long term performance. The closed loop ac gain is dictated by resistors R-136 and R-137. R-137 serves to vary the amount of feedback and act as the servo amplifier gain control. The electrical location of this control makes it suitable for physically placing it with the low level dc circuitry and having no danger of undesired feedback or oscillation. The dc stability of this stage is achieved by the feedback path from the collector of Q-105. This feedback path is a low pass filter comprised of resistors R-138 and R-104, and capacitors C-118 and C-120. It provides good dc negative feedback, but has adequate ac bypassing so that it has no influence on the overall ac gain of the amplifier. The several second warm-up time of the recorder is caused by the time constant of this feedback network. Diode CR-103 is used to improve the bias voltage conditions on the input of Q-105 so that R-141 may be a reasonable size. R-139

is used to pull sufficient quiescent current through Zener diode CR-104, thereby holding its dynamic impedance at a reasonable magnitude. Additional amplification is provided by Q-106 which is capacitor coupled from Q-105 by C-121. The voltage gain of the Voltage Amplifier is approximately 2000.

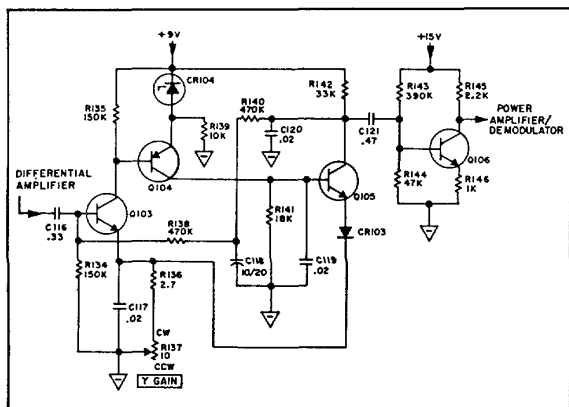

FIGURE 4-9. VOLTAGE AMPLIFIER

4-18. POWER AMPLIFIER/DEMOMULATOR (See Figure 4-10). This section can be roughly divided into two sections: the first section provides the current gain required, and the last provides both additional current gain and acts as a demodulator. This stage consists of transistors Q-107, Q-108, Q-109, and Q-110. Since this is essentially a Class B operating stage, and the output section is a demodulator applying half-wave ac to a permanent magnet dc servo motor, operation of the demodulator section must first be understood before discussing the entire output stage.

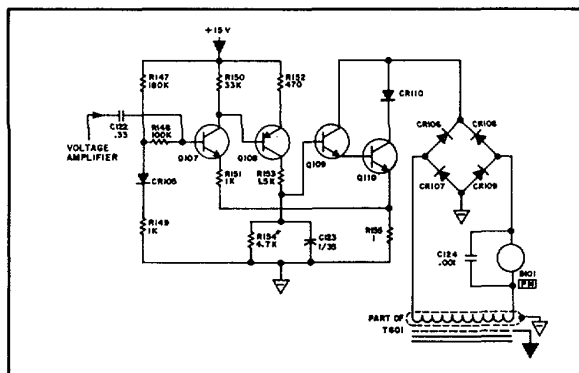

FIGURE 4-10. AMPLIFIER/DEMOMULATOR

4-19. The demodulator is shown in simplified form in Figure 4-11. Power to drive the dc servo motor is taken from a separate shielded winding on power transformer T-601. The direction of the motor rotation is determined by the direction of current through the armature. Control of the motor current is provided by the darlington pair comprised of transistors Q-109, and Q-110, operating essentially Class B. The four modes of operation of the demodulator are determined by the relative phasing of the voltage at Points A and B. Point A is excited by

the line voltage appearing in the secondary of power transformer T-601. The polarity of Point B is determined by the error voltage amplifier output and will be either in phase or 180 degrees out of phase with the line as determined by the error voltage applied to the photochopper.

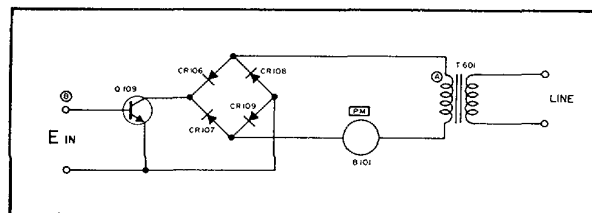

FIGURE 4-11. MOTOR CONTROL AND DEMODULATOR

- Mode 1            Current flows from T-601, through B-101, A- CR-108, CR-110, Q-110, R-115, and through CR-107 back to T-601. The motor will rotate right.
- Mode 2            Current flowing from T-601 is blocked by A- Q-110. No current will flow, and motor B- will not rotate.
- Mode 3            Current flows from T-601 through CR-106, A+ CR-110, Q-110, R-155, CR-109, B-101 B+ back to T-601. The motor will rotate left.
- Mode 4            Current flowing from T-601 is blocked by A+ Q-110. No current will flow, and motor B- will not rotate.

4-20. AC feedback as well as dc feedback is obtained via R-149 and R-155 to the emitter of the first transistor, Q-107. The bias current at the input transistor is designed to pull the output stage very slightly into Class A operation, to the extent that at null, the voltage across the servo motor is approximately 1/3 volt rms. Diode CR-105 in the bias string helps to compensate for the temperature change of  $V_{be}$  of the input transistor Q-107 over the temperature range. Resistor R-153, coupling the second and third transistor, limits the current drain of Q-108 from the 15 volt supply when the output stage is saturated. Diode CR-110 is used to minimize the power dissipation in the output transistor Q-110 when the darlington pair is saturated. Capacitor C-124 is connected directly across the dc servo motor and serves to suppress RFI caused by the motor brushes. The voltage gain of this stage is approximately 6.

4-21. POWER AND REFERENCE SUPPLY (See Figure 4-12). The reference voltage for each axis is independents derived from a Zener controlled dc power supply normally 9 volts. The temperature stability of this supply is better than 0.002% per degree C. This supply also furnished the voltage for the servo amplifier's first three stages. Since the servo amplifier input circuit



combination is floated free of ground at the power transformer, the reference supply serves several purposes: it not only furnishes the stable voltage for the balance circuit, but also furnishes all the power requirements for the servo amplifier with the exception of the Power Transformer T-601 furnishes this power from a shielded secondary through rectifying diodes CR-115 and CR-116 into a peak filter C-125. Two shunt supplies in series furnish 15 volts for the amplifier's power stages and 9 volts for the input stages and balance circuit. An identical but reversed supply furnishes the -9 volts for the zero circuit.

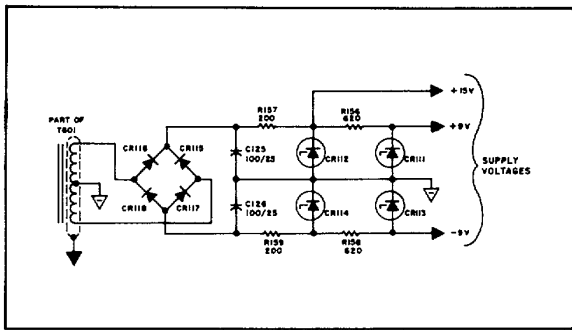

FIGURE 4-12. POWER AND REFERENCE SUPPLY

4-22. NEON DRIVER (See Figure 4-13.) The power supply for the neon bulbs that actuate the photochopper's photo cells is basically a voltage clamp-in circuit comprised of capacitors C-301, C-302 and diodes CR-301, CR-302. On alternate half-cycles, diode CR-301 conducts causing the full power line voltage to be placed across capacitor C-301. This essentially doubles the peak value available to ignite the neon bulbs. Since high brightness neon bulbs are used to efficiently operate the photo cells, and since the firing voltage of a high brightness neon bulb prior to aging may vary greatly, this voltage doubler eliminates the necessity for aged bulbs by providing a maximum voltage that will always exceed the fluctuations of the required firing voltage.

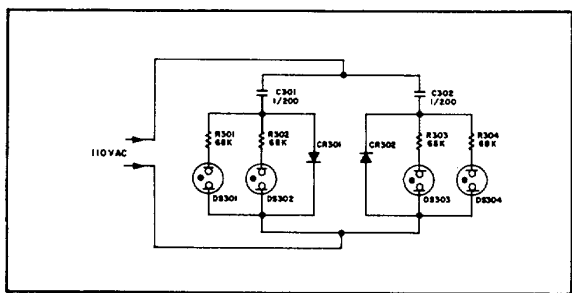

FIGURE 4-13. NEON DRIVER

4-23. AUTOGRIP POWER SUPPLY (See Figure 4-14.) The Autogrip power supply is also located on the amplifier printed circuit board. The power is obtained from the high voltage secondary winding on the main power transformer T-601 and the remainder of the supply is composed of resistors R501 through R505, diodes CR501 through 504, and dual capacitors C501 and C502. Resistor R501 serves as a current limiter and capacitor C501 and C502, as well as diodes CR501 through CR504 form a power supply that places a dc voltage between the grids of the Autogrip table that is equal to + 380V ± 10% and -380V ± 10% referenced to ground. Switch S501 is used to deenergize the Autogrip. A contact closure in the switch grounds the input voltage to the quadrupler rectifier circuit, causing the dc voltage on the Autogrip table to go to zero, thus making the holddown inoperative.

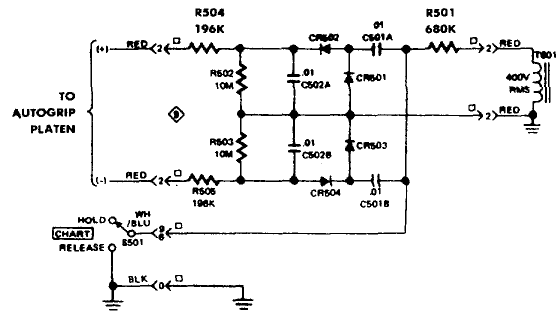

FIGURE 4-14. AUTOGRIP POWER SUPPLY

4-24. PEN DROP SUPPLY (See Figure 4-15.) The power supply for the electric pen lift consists of a low voltage winding on T-601, diode CR-401, resistor R-401 and capacitor C-402. With switch S-401 open, C-402 charges to the peak dc voltage of the supply. When S-401 is closed, the capacitor discharges through the pen solenoid, causing a large peak voltage to be placed across the solenoid for a short period of time. This surge increases the pull-in force of the solenoid while the resistor R-401 provides a lower maintained current after the capacitor has partially discharged. C-401 suppresses switch arcing.

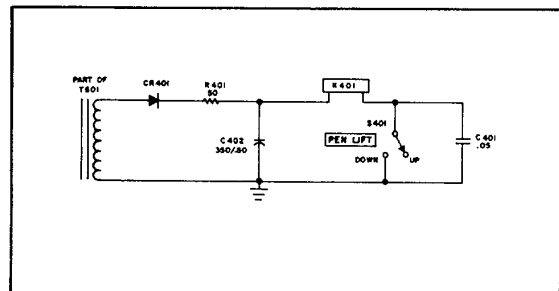

FIGURE 4-15. PEN DROP SUPPLY

## SECTION V

## MAINTENANCE, PERFORMANCE CHECKS, AND ADJUSTMENTS

## 5-1. INTRODUCTION

5-2. This section provides information for maintenance, performance testing, functional checks, and adjustments of the 7035B X-Y Recorder. Maintenance procedures, tests, and adjustments will ensure that the instrument conforms to specifications. Functional checks maintain the instrument in an operational condition. If the instrument fails to meet specifications, or is inoperable, refer to Section VII, Troubleshooting.

## 5-3. PREVENTIVE MAINTENANCE

## 5-4. GENERAL

5-5. The instrument must be maintained properly for accurate, trouble-free operation. This requires periodic lubrication, performance checks, and visual and electrical checks. In accordance with good maintenance procedures for all precision measuring instruments, Hewlett-Packard recorders should be protected from dust. Cover the instrument when not in use.

## 5-6. ENVIRONMENTAL OPERATION

5-7. This instrument is designed to operate over an ambient temperature range of approximately 0°C to 55°C. Operation under other conditions will produce inaccurate results and may cause damage to the recorder. In areas with high humidity, graph paper may become distorted, affecting the accuracy of the grid lines. The area of operation should also be as free as possible of air contamination (soot, smoke, fumes, etc). Excessive air contamination will require more frequent cleaning.

## 5-8. CLEANING

5-9. Thorough cleaning should be performed periodically. Intervals are determined by type of operation, local air contamination, and climatic conditions. Generally, under normal use and conditions, cleaning intervals should be nine to twelve months. Cleaning routine should include the following:

a. Remove platen and bottom cover. See paragraph 5-18.

b. In accessible areas and where there is only dust accumulation, cleaning can be accomplished with an air gun. In more accessible areas and where the air gun will not remove dirt, dust, or ink, accumulations should be removed with a sponge or cloth saturated in plain soap and warm water, then wiped dry.

c. Every eighteen to twenty-four months, gears should be cleaned thoroughly with a solvent and relubricated. Do not use soap or water on these components.

d. The following method is recommended for cleaning Autogrip table. Dust and other accumulation of foreign films on the table surface will lower the paper holding force. The film may be removed and the table holding ability restored by using the cleaning procedure. If strong chemicals, abrasives, or too much water is used, the table may be permanently damaged. To clean:

1. Remove pen and paper from recorder.
2. Select a mild liquid soap. Do not use products with abrasive or corrosive chemicals.
3. Use soft cloth that will not scratch the surface but will absorb water.
4. Saturate the cloth in warm, soapy water. Wring cloth until majority of water has been removed.
5. Wipe table surface with damp cloth until Autogrip table is clean.

**CAUTION** Never let water stand on Autogrip surface. It may permanently damage the table.

6. Wipe any moisture from surface.
7. Allow a few minutes to dry before recording.

**CAUTION** Do not use solvents or silicone-based cleaners of any type on the Autogrip platen.

## 5-10. POTENTIOMETER CLEANING

5-11. Irregular or "jumpy" plots produced by smooth signals on a properly adjusted recorder may indicate worn or dirty balance potentiometers or wipers. To clean the potentiometer, spray the potentiometer along its entire length with Slidewire Cleaner (Part No. 5080-3605). Rapidly move the carriage arm or pen carriage several full scale excursions. Spray the wiper directly with Slidewire Cleaner. Thoroughly saturate a Kimwipe (Kimberly-Clark Type 900-S) or a cotton swab with Slidewire Cleaner. Rub the potentiometer (wire mandrel and return strip) along its entire length, using the moistened tissue or swab (see Figure 5-1). Note any discoloration of the tissue or swab after rubbing the potentiometer. Repeat the cleaning procedure until there is no stain, then clean once more to insure that all contaminants have been removed. After cleaning, the potentiometer (wire mandrel and return strip) must be lubricated with the furnished Slidewire Lubricant (Part No. 5080-3635). This lubrication will reduce wear and chemical contamination of the balance potentiometer assembly (see Figure 5-2).



FIGURE 5-1. POTENTIOMETER CLEANING

## 5-12. LUBRICATION

5-13. The Model 7035B is a precision instrument. Gears and other moving parts have very close tolerances. Lubrication of gears should be performed sparingly. Over lubrication may produce more friction than no lubrication. Intervals between periodic lubrication are determined by the type of operation, local air contamination, and climatic conditions. Generally, under normal use and conditions, the recorder should be lubricated every nine to twelve months. Complete relubrication should be performed every two years. All ball bearings are prelubricated by the manufacturer and require no further lubrication.

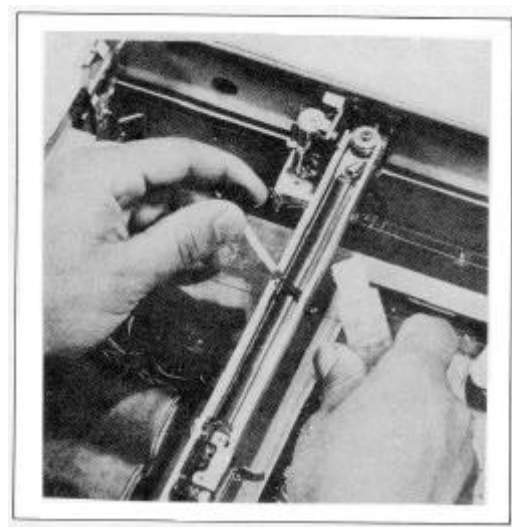

FIGURE 5-2. POTENTIOMETER LUBRICATION

a. Apply a thin film of lubricant on the X and Y gear drives (including idler gear). Recommended grease is Aeroshell MIL-G-7118A and 3276A or HP Part Number 6040-0222.

**CAUTION** Lubricant must not spill onto the X-axis drive belt.

## 5-14. VISUAL LUBRICATION

5-15. During periodic cleaning and lubrication, a planned visual inspection should be performed. The following steps are a general approach:

- a. Check both the X and Y drive gears for proper adjustment (a very slight amount of backlash) and any worn or damaged teeth.
- b. Inspect X-axis drive cable pulleys for any binding.
- c. Insure that both servo motors are mounted securely.
- d. Move pen carriage up and down, listening for scrapes, grinding noises, etc., while feeling for any binding in the movement. Repeat this procedure for the carriage arm.
- e. Check cables of both axes for fraying or rubbing.
- f. A check of components should include inspection for evidence of overheating, loose connections, cracked circuit boards, etc.

## 5-16. MECHANICAL MAINTENANCE

### 5-17. DISASSEMBLY/ASSEMBLY

5-18. Access to components for maintenance, checks, and adjustments requires removal of exterior parts

first, such as panels, covers, etc. To disassemble/assemble, perform the following steps:

**NOTE** Before proceeding with disassemble/assemble procedure, remove disposable pen and ac power cord.

a. Bottom Cover - Stand recorder on side. Remove 8 No. 6-32 machine screws. Input attenuators, amplifiers, balance circuit, and power supply are accessible.

b. Interior - For access to circuit side of printed circuit board, remove 3 No. 8-32 nuts holding control panel frame to recorder, 3 No. 6-32 screws holding printed circuit board, and 6 front panel knobs. Entire board/frame assembly tilts out. See Figure 5-3.

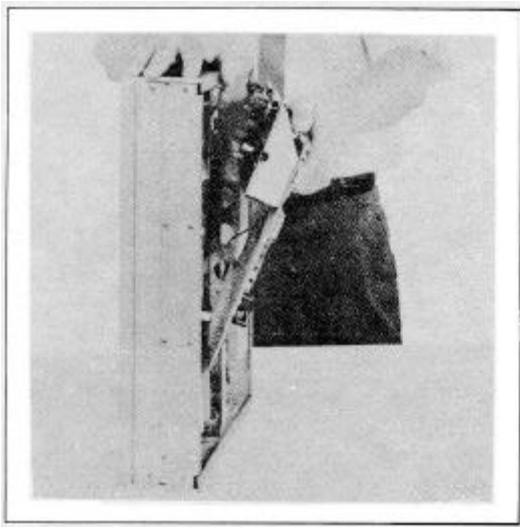

FIGURE 5-3. TILTING OUT ENTIRE CIRCUIT BOARD ASSEMBLY

c. Autogrip Table - Place carriage at far right of travel. Remove 4 No. 8-32 mounting screws. Slide platen toward side of recorder. Disconnect 2 Autogrip power leads before easing platen all the way out.

d. Rear Hood - Pull upward and disengage spring clips.

e. Wing Brackets - Remove 2 No. 10-32 machine screws per bracket. See Figure 2-1.

f. Side Panel - Remove bottom cover. Carefully insert small, sharp, slot type screwdriver behind upper edge of panel and gently pry outward. Panel free (see Figure 5-4). Progressively pull upper edge free, working from one end to other until panel pops off. To install, hook upper edge of side panel over top of frame or into groove. Swing lower edge of panel toward bottom of recorder. Force past outer surface. Snap into place.

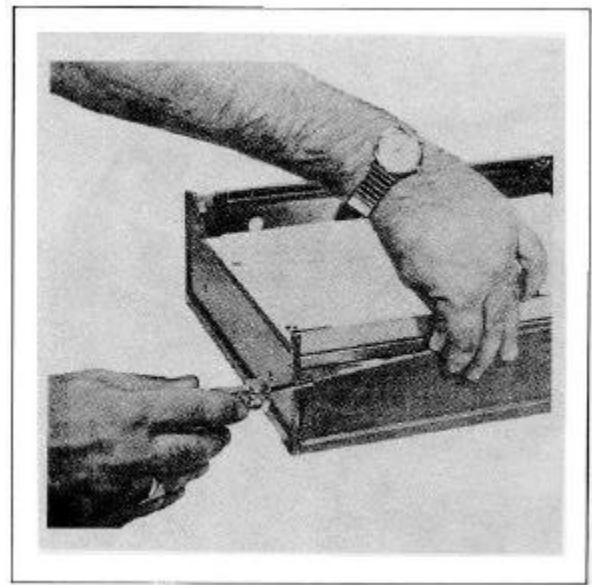

FIGURE 5-4. SIDE PANEL REMOVAL

#### 5-19. CARRIAGE ARM REMOVAL

5-20. To remove, perform the following steps.

a. Remove rear hood and platen. See paragraph 5-18.

b. Unsnap pen scale at rear and remove from arm. See Figure 5-5.

c. Remove X-axis slidewire. See paragraph 5-24.

d. Remove 2 shouldered screws at upper end holding pen carriage arm. Arm lifts off its motor block. See Figure 5-6. Do not damage wires connecting potentiometer to motor block. Slide arm toward rear, separating it from lower carriage track. Small wheel which rides in track is not retained and may fall off.

e. After reassembling carriage arm, align Y-axis. See paragraph 5-73.

#### 5-21. PEN CARRIAGE REMOVAL

5-22. The pen carriage may be removed for replacement or service as follows:

a. Remove carriage arm. See paragraph 5-20.

b. Remove nylon cable from around drive and return pulleys. Slide carriage forward and over return pulley.

c. After reassembling pen carriage, adjust pen carriage. See paragraph 5-71.

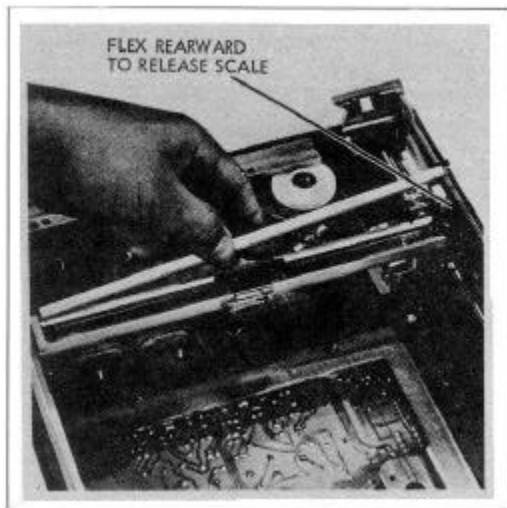

FIGURE 5-5. PEN SCALE REMOVAL

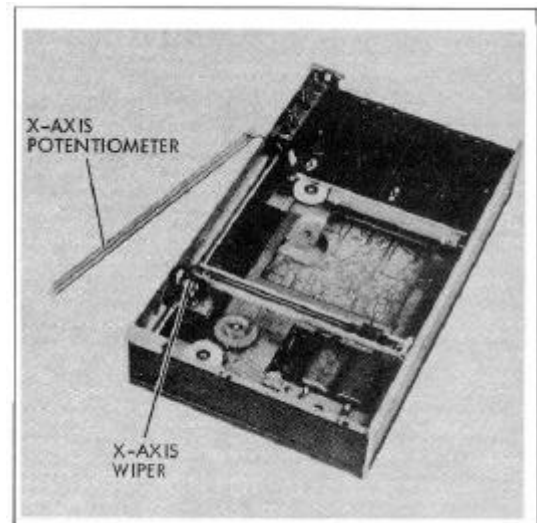

FIGURE 5-7. REMOVAL OF X-AXIS REBALANCE POTENTIOMETER

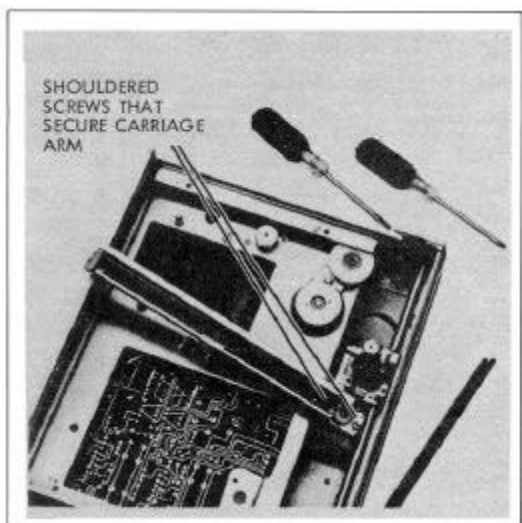

FIGURE 5-6. CARRIAGE ARM REMOVAL



FIGURE 5-8. X-AXIS WIPER PROTECTION

5-23. POTENTIOMETER REPLACEMENT - X-AXIS

5-24. The mandrel and its mounting channel are an integral unit, available only as a single item. Install as follows:

- a. Remove rear hood and platen. See paragraph 5-18.
- b. Remove 2 screws mounting slidewire assembly to frame. See Figure 5-7.
- c. Unsolder 3 wires, noting order of leads connected to slidewire.
- d. Move slidewire assembly upwards, being careful not to damage wiper. See Figure 5-8.

- e. Install new slidewire assembly, Part No. 07035-80730.

5-25. WIPER REPLACEMENT - X-AXIS

5-26. The wiper is made of a soft metal to absorb wear. It is located on the pen motor block at the upper end of the carriage arm. New wiper assemblies should be obtained from the factory and installed as follows:

**CAUTION**      **Damage to the flat mandrel slidewire may result if other than factory supplied wiper is used.**

- a. Remove rear hood and platen. See paragraph 5-18.
- b. Snap pen lift solenoid out of its spring holder and remove holder and X-axis pointer by removing 1 mounting screw.
- c. Remove wiper assembly mounting screw and install new wiper, Part No. 5060-4570.

5-27. POTENTIOMETER REPLACEMENT - Y-Axis

5-28. This unit is located in the carriage arm and is part of the carriage channel. The channel and potentiometer are replaced as one unit. Replace as follows:

- a. Remove rear hood and platen. See paragraph 5-18.
- b. Remove carriage arm and X-axis slidewire. See paragraphs 5-20 and 5-24.
- c. Unsolder 3 wires, noting order of leads connected to slidewire.
- d. Install new slidewire assembly, Part No. 07035-80750.

5-29. WIPER REPLACEMENT - Y-Axis

5-30. The wiper is made of a soft metal to absorb wear. The wiper is located on the pen block. New wiper assemblies should be obtained from the factory and installed as follows:

**CAUTION**      **Damage to the flat mandrel slidewire may result if other than factory supplied wiper is used.**

- a. Remove rear hood and platen. See paragraph 5-18.
- b. Remove pen scale. See paragraph 5-20.
- c. Remove X-axis potentiometer. See paragraph 5-24.
- d. Remove pen carriage arm. See paragraph 5-22.
- e. Remove wiper assembly from pen block by unscrewing 1 0-80 screw and nut.
- f. Install new wiper, Part No. 5080-7706.
- g. After reassembling pen carriage, adjust pen carriage. See paragraph 5-71.

5-31. SERVO MOTOR MAINTENANCE

5-32. The magnetic field strength of the servo motor will weaken if the rotor is removed from within the magnet. Upon reassembly, it will be impossible for the motor to return to specified performance. Therefore, only servo motor replacement and brush replacement or adjustment are recommended.

5-33. X-AXIS SERVO MOTOR REPLACEMENT

5-34. To remove:

- a. Remove rear hood and platen. See paragraph 5-18.
- b. Remove 2 No. 4-40 setscrews and slip flywheel off motor shaft.
- c. Stand recorder on side. Remove bottom cover. See paragraph 5-18.
- d. Unsolder 2 wires, noting their polarity. Remove 1 capacitor.
- e. Using Phillips screwdriver, remove 2 screws mounting motor. See Figure 5-9.

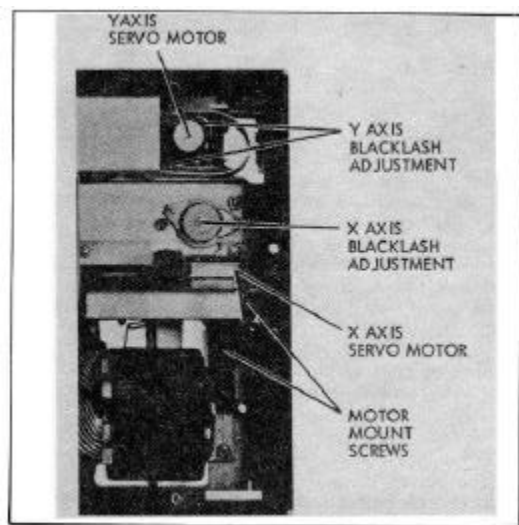

FIGURE 5-9. SERVO MOTOR MAINTENANCE AND BACKLASH ADJUSTMENTS

- f. Tilt motor so that drive belt can be disengaged. Remove motor.
- g. Reverse above steps to install.
- h. Adjust X-axis drive belt. See paragraph 5-77.

5-35. Y-AXIS SERVO MOTOR REPLACEMENT

5-36. To remove:

- a. Remove rear hood. See paragraph 5-18.
- b. Move pen carriage to extreme left hand position.
- c. Stand recorder on right side. Remove bottom cover. See paragraph 5-18.

- d. From bottom of recorder, unsolder 2 wires, noting their polarity. Remove 1 capacitor.
- e. Remove 2 screws and clamps mounting motor. Withdraw motor from block.
- f. Reverse above steps to install.
- g. Adjust Y-axis drive gears. See paragraph 5-69.

5-37. BRUSH REPLACEMENT

5-38. If it appears the brushes must be replaced, perform the following steps without removing the motor from the recorder.

- a. Unsolder two motor leads and remove two solder lug mounting screws. (Note the polarity of the lugs and mark so that when reassembling a phase reversal will be avoided.)
- b. Unhook brush spring from under tab on each lug. Pivot brush springs outward and pull brushes out of their holes. Remove solder lugs and brushes.
- c. Remove two screws retaining end bell.
- d. Carefully pull rear end bell and bearing assembly from rotor, while holding magnet in place against front end bell. Make sure rotor remains in place inside motor as rear end bell is removed. If necessary, push rear end of shaft with a pencil point or similar object as rear end bell and bearing are removed.
- e. Blow or brush dust from magnet, rotor, and rear end bell brush holes. Use an air hose if possible. Be careful not to lose ball bearing or bearing spacer shims.
- f. Replace rear end bell and bearing assembly. Secure with two long screws removed earlier.
- g. Replace two solder lugs in end bell slots and secure with screws.
- h. Install each brush in brush hole making certain that arc on bottom of brush matches curvature of commutator. Pigtail leads should rise straight up out of brush hole until brush springs have been installed. Use a pencil point to adjust pigtail and to push brush all the way down into brush hole.
- i. Swing brush springs back to their original position, engaging slots on top of brushes and hook rear end of each spring under tab on terminal lug. Fold pigtails into top of spring slot so they are below surface of end bell. Solder motor wires to the correct lugs.
- j. Operate recorder. If pen drives into stops instead of seeking null, motor polarity has been inadvertently reversed. Reconnect motor wires to opposite terminal lugs.
- k. Run recorder through complete performance check. If brushes are not seating well, apply a 0.3 Hz sine wave to recorder, adjust to 85% of full scale travel, and let recorder run for an hour.

**NOTE: If either servo motor was removed, install per paragraph 5-34 or 5-36.**

5-39. CORRECTION OF STICKING MOTOR BRUSHES

5-40. The most common cause of a sticking motor brush is an interference between the motor body and the brush lead wire, preventing the brush from moving downward. By carefully repositioning the lead, the brush can be freed. Other possible causes of a sticking brush are burrs in its holes or an accumulation of foreign matter. If either of these is the cause, the motor will have to be removed and cleaned or replaced.

5-41. Y-AXIS RESTRINGING

5-42. To restring, using Y-axis cable assembly, Part No. 07035-61420, perform the following procedure:

- a. Remove rear hood and platen. See paragraph 5-18.
- b. Remove carriage arm and pen block. See paragraphs 5-20 and 5-22.
- c. Attach free end of tension spring to the hook on pen block. Insert knotted end of new nylon cord assembly in groove of pen block. See Figure 5-10.

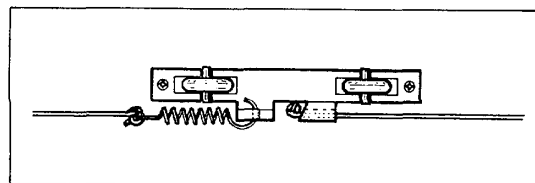

FIGURE 5-10. NYLON CABLE (ATTACHMENT TO PEN BLOCK)

- d. Slide pen block into carriage arm. Ensure cable is between pen block and slidewire. Care should be taken not to damage wiper.
- e. Loop cord around upper and lower pulleys.
- f. Reassemble.
- g. Make cable tension check. See paragraph 5-65.

5-43. X-AXIS RESTRINGING

5-44. To restring, using X-axis cable assembly, Part No. 5080-3627, perform the following procedure:

- a. Remove rear hood and platen. See paragraph 5-18.
- b. Position carriage arm at convenient location and fasten securely with tape to prevent movement. Remove old cable.
- c. Make small loop in one end of cable and clinch with cable crimp. See Figure 5-11.

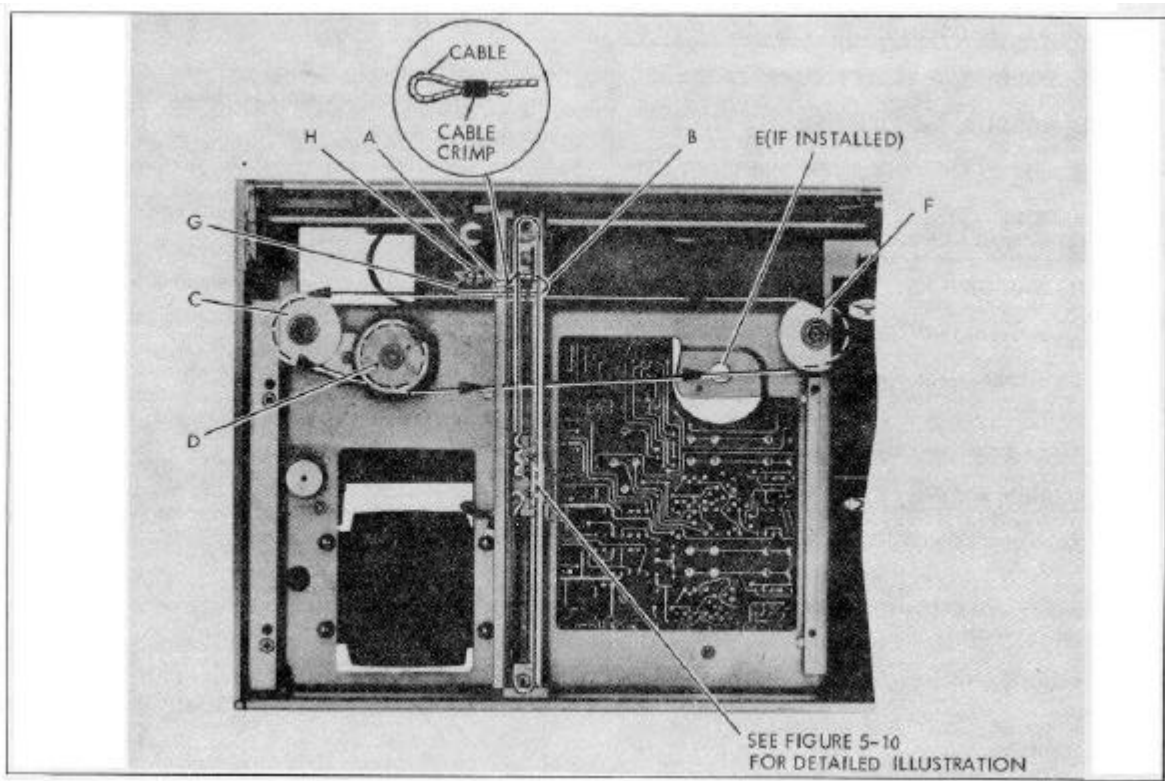

FIGURE 5-11. RESTRINGING DIAGRAM

d. Attach loop to center of cable yoke (Point A). Route cable around right-hand side of cable yoke (Point B), and pass it in front of cable yoke to pulley C. Continue around pulley C in a counterclockwise direction to sheave D. Make one counterclockwise turn around sheave D.

e. If recorder is equipped with a retransmitting potentiometer (Option 003) follow this step. If not, go on to step f. From sheave D start cable in center of sheave E. Make two turns in a counterclockwise direction, passing cable beneath itself after each turn. After second turn run cable through the slot on bottom edge of sheave to hole in the sheave. Run cable through the hole, and under screw and washer on top of sheave. Tighten screw. Pass cable through slot on top edge of sheave. Continue around sheave two more turns in a counterclockwise direction, passing each turn beneath itself, and continue to pulley F.

f. Pull cable around pulley F in counterclockwise direction, pass it in front and around left-hand edge of cable yoke (Point G) and pass it to screw (Point H) on Y motor block.

g. Pass cable around screw (Point H) in clockwise direction. Firmly pull on cable (to keep the cable taut), and tighten screw.

**NOTE:** There is a nut on the bottom of Nut H. Make sure this is tight.

h. Check cable tension as described in paragraph 5-75.

i. Clip off the excess wire.

## 5-45. ELECTRICAL MAINTENANCE

### 5-46. REQUIREMENTS

5-47. The Model 7035B requires minimum electrical maintenance. It is carefully aligned during manufacture. However, if the recorder ever requires alignment, specific adjustment procedures are detailed in this section. Section VII, Troubleshooting, contains additional material.

## 5-48. PERFORMANCE TESTS

### 5-49. CRITERIA

5-50. This instrument should meet the following Hewlett-Packard performance standards to assure operation within specifications. If this instrument fails to meet the following test specifications, refer to adjustment procedures within this section or Section VI, Troubleshooting.

### 5-51. TEST EQUIPMENT

5-52. The instruments and accessories required for completing performance tests are listed in Table 5-1.



TABLE 5-1. RECOMMENDED TEST EQUIPMENT

1. HP MODEL 740B DC VOLTAGE STANDARD
2. HP MODEL 3310A FUNCTION GENERATOR
3. HP MODEL 410C or 427A DC VOLTMETER
4. HP MODEL 202A LOW FREQUENCY FUNCTION GENERATOR

5-53. INITIAL CHECKS

5-54. To perform initial performance checks:

- a. Set 115/230 selector switch to appropriate power source.
- b. Connect power cable.
- c. Install pen and paper.
- d. Position POWER/SERVO toggle switch to ON-ON.
- e. Position CHART toggle switch to HOLD. Paper is held down securely.
- f. Position PEN toggle switch to DOWN.
- g. Connect DC Standard to high and low (+ and -) Y-axis inputs.
- h. Apply positive dc voltage. Pen moves upscale.
- i. Return pen to zero position.
- j. Disconnect DC Standard from Y inputs. Connect to X inputs.
- k. Apply positive dc voltage. Pen moves across recording area.

5-55. Y-AXIS ACCURACY AND LINEARITY

- a. Connect DC Standard to Y input terminals.
- b. Place pen at exactly zero on Y-axis and at 5 inches (12.5 cm) on X-axis.
- c. Apply 0.7 volt to Y input terminals.
- d. Pen should stop at 7 inches (18 cm) within  $\pm 0.014$  in. (0.34 mm).
- e. If pen does not stop within tolerance, adjust calibration control (R-126).
- f. Reduce voltage applied in steps of 0.1V at each step.
- g. After each step, pen should stop at 1 in. (2 cm) intervals within 0.014 in. (0.34 mm).

5-56. X-AXIS ACCURACY AND LINEARITY

5-8

- a. Connect DC Standard to X input terminals.
- b. Place pen at exactly zero on X-axis and at 3.5 in. (9 cm) on Y-axis.
- c. Apply 1 volt to X input terminals.
- d. Pen should stop at 10 inches (25 cm) within  $\pm 0.020$  in. (0.5 mm).
- e. If pen does not stop within tolerance, adjust calibration control (R226).
- f. Reduce voltage applied in steps of 0.1V at each step.
- g. After each step, pen should stop at 1 in. (2 cm) intervals within 0.020 in. (0.5 mm).

5-57. Y-AXIS SLEWING SPEED

- a. Hook up recorder as shown in Figure 5-12.

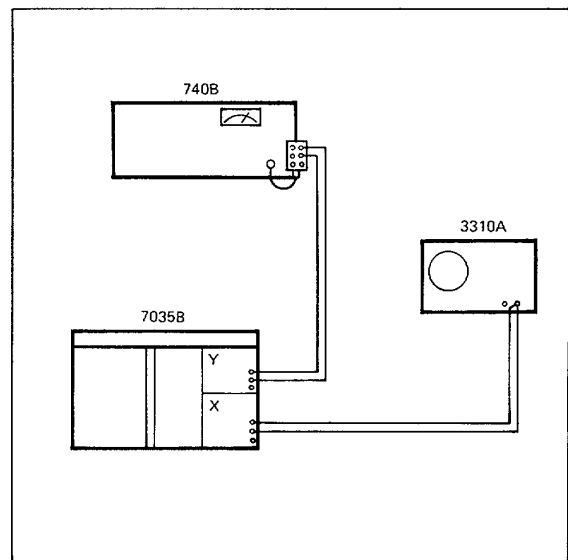

FIGURE 5-12. Y-AXIS SLEWING SPEED TEST SETUP

- b. Set Function Generator to 0.5 Hz and triangular wave output with peak-to-peak output of 1V.
- c. Position pen to bottom grid line.
- d. Apply 0.7 VDC to Y input at beginning of an X excursion.
- e. Measurement is shown in Figure 5-13.

5-58. X-AXIS SLEWING SPEED

- a. Hook up recorder as shown in Figure 5-14.
- b. Set Function Generator to 0.715 Hz and a triangular wave output with peak-to-peak output of 0.7V.
- c. Position pen to bottom grid line.

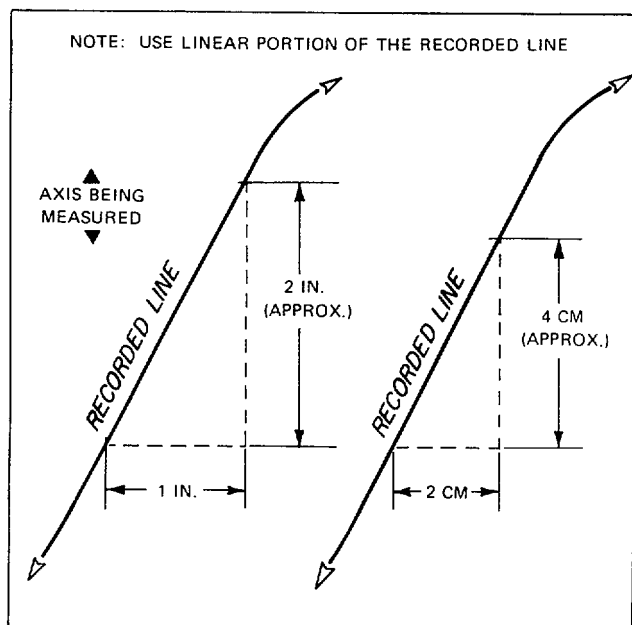

FIGURE 5-13. SLEWING SPEED DETERMINATION

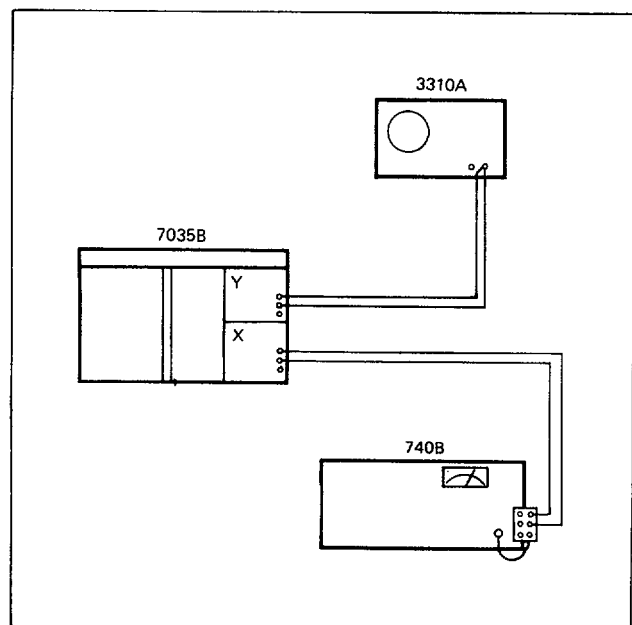

FIGURE 5-14. X-AXIS SLEWING SPEED TEST SETUP

- d. Apply 1 VDC to X input at beginning of a Y excursion.
- e. Measurement is shown in Figure 5-13.

5-59. COMMON MODE REJECTION

5-60. DC REJECTION

- a. Set RANGE switch to 1 mV/in. (0.4 mV/cm). Connect input terminals with short between high (+) and guard, and 1K Resistor between low (-) and guard.
- b. Connect DC Standard between Y guard terminal and ground.
- c. Set DC Standard to 500 volts.
- d. Pen will overshoot and settle to a level not exceed 0.16 inch (4.0 mm) from initial position on chart.
- e. Repeat at all fixed attenuator positions for Y inputs.
- f. Repeat test for X-axis. Pen deflection is same.

**CAUTION** Before removing input leads, reduce signal to zero.

5-61. AC REJECTION

- a. Set RANGE switch to 1 mV/in. (0.4 mV/cm). Connect the 1k ohm resistor between the high (+) and low (-) terminals, and a short between the low (-) and guard terminals.
- b. Pen deflection shall not exceed 0.1 inch (2.54 mm) with pen in any position on paper.
- c. Set Function Generator to 10 V peak-to-peak sine wave and sweep frequency  $\pm 3$  Hz around line frequency.
- d. Pen deflection shall not exceed 0.2 in. (5 mm) with pen at any position on paper.
- e. Repeat at all fixed attenuator positions for Y inputs.
- f. Repeat test for X-axis. Pen deflection is same.

5-62. MECHANICAL ADJUSTMENTS

5-63. PROCEDURE

5-64. Any adjustment to the instrument is deemed necessary only when it is determined the instrument is out of adjustment per specifications, but not malfunctioning due to component failure.

5-65. Y-AXIS DRIVE STRING TENSION CHECK/ADJUSTMENT

5-66. The Y cable tension may be verified by measuring the force required to move the pen carriage downscale while the motor is locked. This required force shall be between the limits of 6 ounces and 12 ounces. To perform the procedure, it is necessary to first remove the rear hood and platen. The procedure is shown in Figure 5-15.

5-67. If the string tension is not correct, the string must be lengthened or shortened to attain the desired tension. This can be accomplished by removing the pen block from the pen arm and retying the knot on the end of the string. See paragraph 5-42.

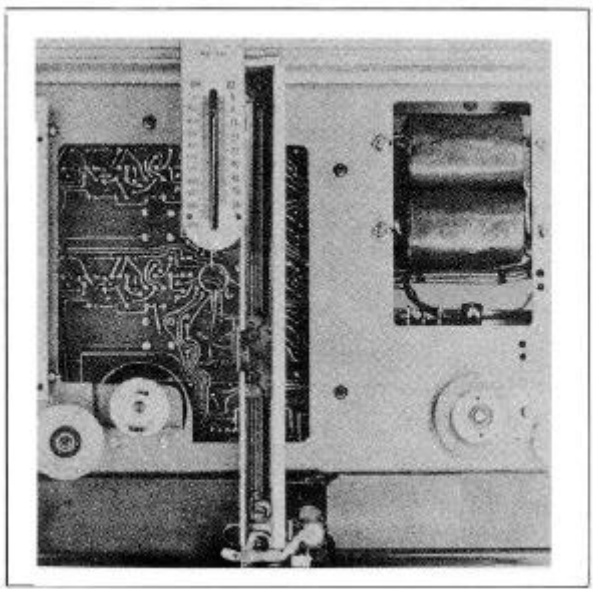

FIGURE 5-15. Y-AXIS DRIVE STRING TENSION CHECK

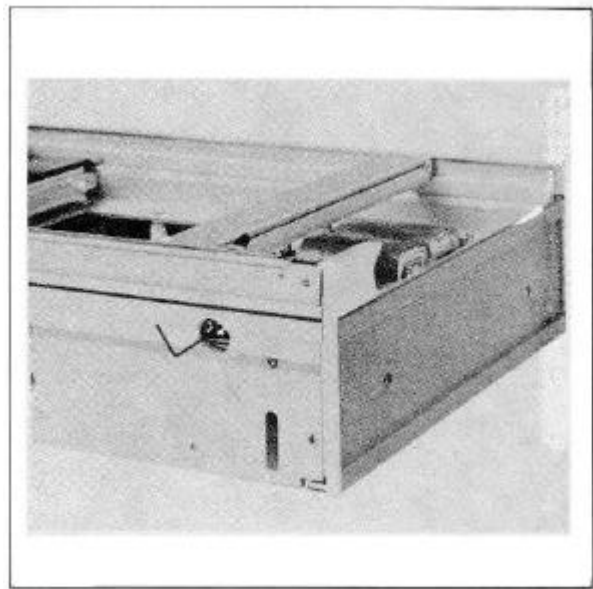

FIGURE 5-16. Y-AXIS BACKLASH ADJUSTMENT (GEAR ADJUSTING SCREW)

5-68. Y GEAR TRAIN BACKLASH ADJUSTMENT

5-69. The Y-axis drive system alignment requires adjusting two gears. These two gears must be adjusted for backlash in proper sequence for best results.

- a. Remove rear hood. See paragraph 5-18.
- b. Remove rear side panel. See paragraph 5-18.
- c. Snap pen lift solenoid out of its holder.
- d. Move pen carriage to left until the gear adjusting setscrew at rear of pen motor block is in line with large access hole in rear wall. See Figure 5-16.
- e. Loosen gear locking screw in upper left corner of pen motor block (Figure 5-17).
- f. Lightly push idler gear toward pen drive, and turn adjusting screw in or out to attain minimum backlash between two set gears.
- g. Tighten gear locking screw.
- h. Move pen carriage to extreme left-hand position and stand recorder on its right side.
- i. Remove bottom cover.
- j. Slightly loosen two motor clamping screws from bottom of the recorder. Rotate motor slightly, first in one direction and then in the other, while moving pen gear back and forth until motor pinion rotates freely with minimum backlash. This procedure varies mesh between motor pinion and pen drive gear due to an eccentric mounting shoulder. A slight amount of backlash is desirable for optimum operation (See Figure 5-18).

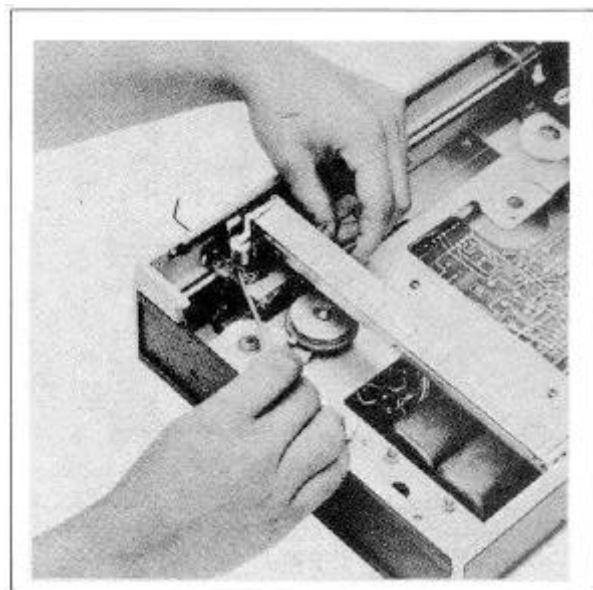

FIGURE 5-17. Y-AXIS BACKLASH ADJUSTMENT (GEAR LOCKING SCREW)

k. Tighten motor clamping screws and recheck for optimum backlash.

l. Reassemble recorder.

5-70. Y-AXIS PEN CARRIAGE ADJUSTMENT

5-71. The pen block rolls in the carriage arm on four plastic rollers. To adjust these rollers:

- a. Move pen block to bottom of arm so 2-56 Bristol setscrew in block is aligned with notch in side of arm, see Figure 5-18.

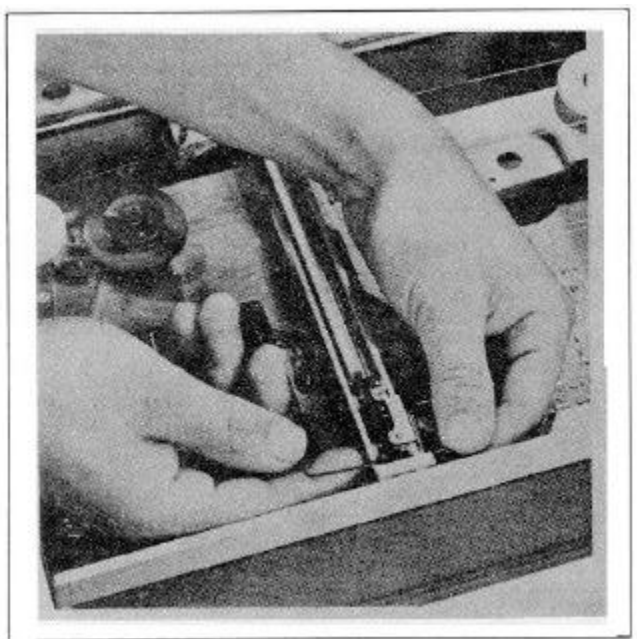

FIGURE 5-18. Y-AXIS PEN CARRIAGE ADJUSTMENT

b. Adjust setscrew to minimize sideplay of block with arm (Adjustment wrench provided in Accessory kit.)

c. Move pen block to upper end of arm so as to align upper setscrew with notch at upper end of arm. Repeat operation.

**NOTE: Care should be taken not to adjust out all sideplay. This will cause mechanical drag and result in a poor trace.**

#### 5-72. Y-AXIS ALIGNMENT

5-73. If a vertical pen trace deviates from perpendicular when compared with correctly aligned paper grids, the carriage arm should be adjusted as follows:

- a. Remove rear hood. See paragraph 5-18.
- b. Remove pen scale. See paragraph 5-20.
- c. Remove X-axis slidewire to prevent accidental damage. See paragraph 5-24.
- d. Replace pen in notched holder.
- e. Partially loosen 2 shouldered screws, A and B, at upper end of arm, see Figure 5-19.
- f. Manually move arm in indicated direction until pen draws a line exactly parallel to vertical grid lines on graph paper.
- g. Retighten both screws. Recheck alignment. Remove pen.
- h. Reassemble.

#### 5-74. X-AXIS CABLE TENSION CHECK/ADJUSTMENT

5-75. The X cable tension should be verified by measuring the force required to displace it at a given distance. With the arm at the extreme right, the force required to displace (in a plane parallel to the control panel and in a direction toward the front of the unit) the center of the longest span of the cable 1/4 inch past the vertical wall of the motor assembly trough shall be between the limits of 15 ounces and 32 ounces. See Figure 5-20. Some adjustment is possible by loosening and repositioning idler pulleys.

5-76. If adjustment is not possible by moving pulleys, a new cable must be installed, making sure that at time of installation the tension is correct. See paragraph 5-44.

#### 5-77. X-AXIS DRIVE BELT TENSION CHECK/ADJUSTMENT

5-78. The X-axis drive belt tension may be verified by measuring the force required to move the carriage arm to the right while the drive sheave is locked. This required force shall be between the limits of 20 ounces and 30 ounces. See Figure 5-21.

5-79. If adjustment is necessary:

- a. Remove platen and bottom cover. See paragraph 5-18.
- b. Slightly loosen two motor mounting screws from bottom of recorder. See Figure 5-22.
- c. Rotate motor in indicated direction until desired tension attained.
- d. Check belt tension. If force not between the limits of 20 and 30 ounces, repeat above steps.
- e. Retighten motor mounting screws.
- f. Reassemble.

#### 5-80. X-AXIS DRIVE BELT REPLACEMENT

5-81. To replace the X-Axis drive belt proceed as follows:

- a. Remove rear hood, platen, and bottom cover. See paragraph 5-18.
- b. Loosen two motor mounting screws from bottom of recorder (see Figure 5-22) and rotate motor until belt is as loose as possible.
- c. Remove two clamps holding pulley assembly and carefully lift assembly outward. Old belt will slip off. Remove from around motor.
- d. Install new belt, Part No. 1500-0043.
- e. Replace pulley assembly and clamps.
- f. Adjust belt tension. See paragraph 5-77.
- g. Reassemble.

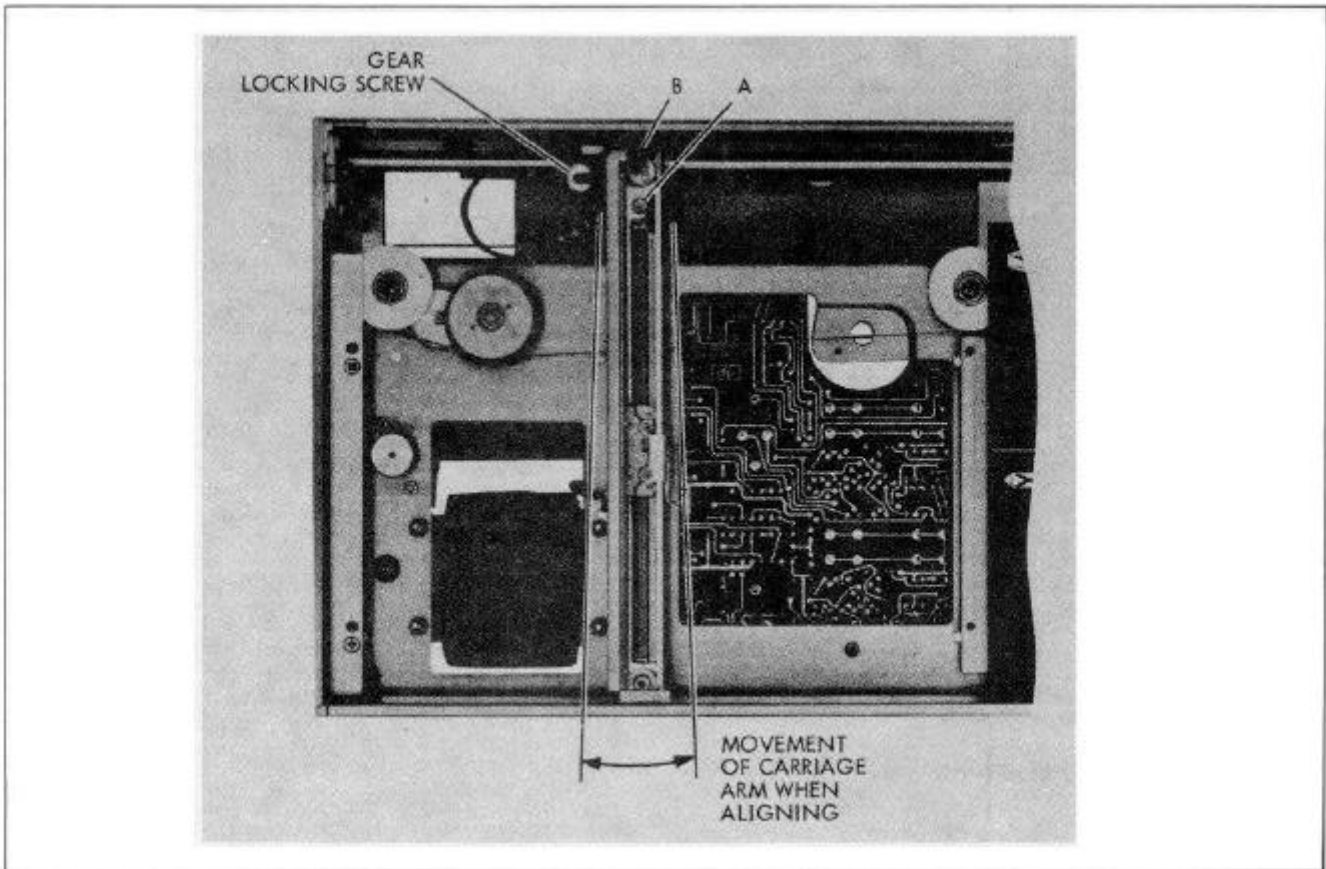

FIGURE 5-19. Y-AXIS ALIGNMENT

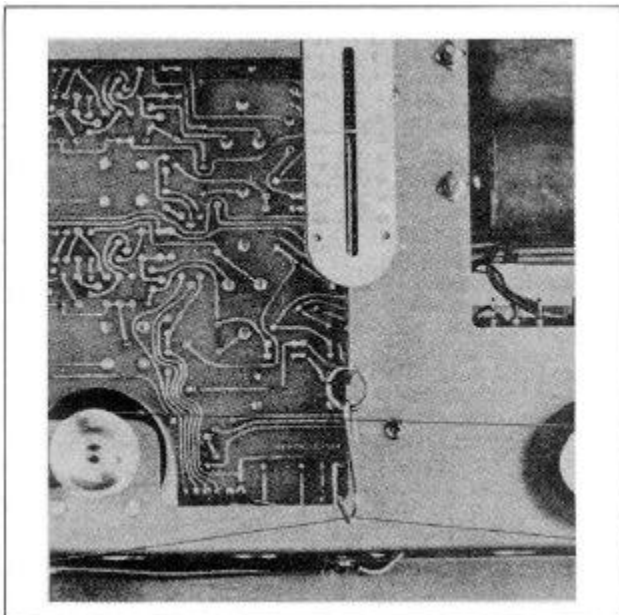

FIGURE 5-20. X-AXIS CABLE TENSION CHECK

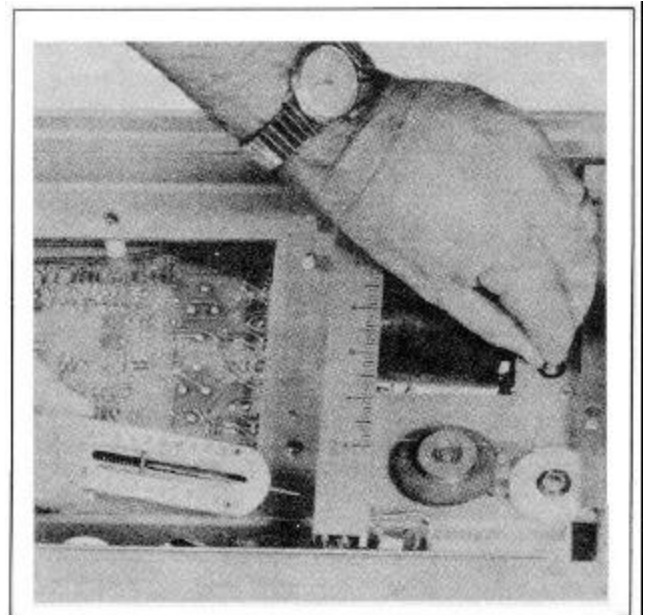

FIGURE 5-21. X-AXIS DRIVE BELT TENSION CHECK

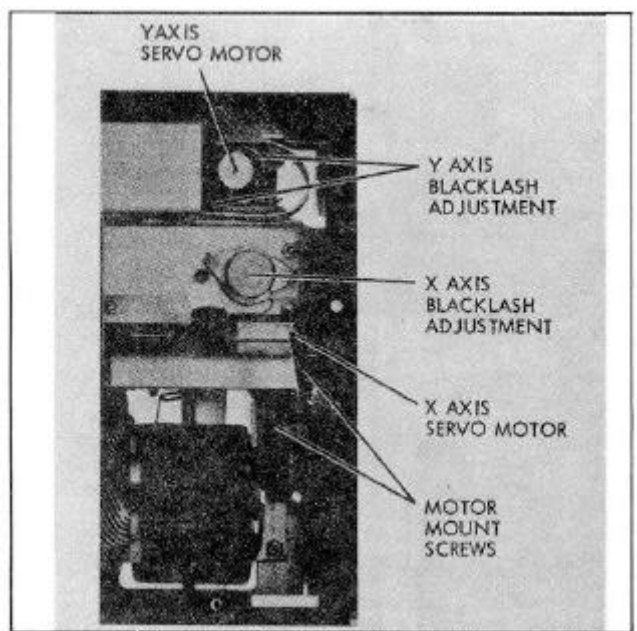

FIGURE 5-22. DRIVE TRAIN ADJUSTMENTS

5-82. X GEAR TRAIN BACKLASH ADJUSTMENT

5-83. Backlash of the gear drive system may be adjusted as follows:

- a. Remove rear hood, platen, and bottom cover. See paragraph 5-18.
- b. Using a 1/4 inch nut driver, slightly loosen two clamps which mount X-axis pulley and pinion on underside of chassis. See Figure 5-22.
- c. Using thumb and fingers, rotate housing first in one direction and then other, while moving pen arm from side to side, until gear rotates freely with minimum backlash. A slight amount of backlash is desirable for optimum operation.
- d. Tighten mounting clamps and recheck for minimum backlash. If minimum backlash not attained, repeat above steps.
- e. Reassemble.

5-84. X-AXIS TRACK BEARING ADJUSTMENT

5-85. Adjustment of the X-axis track bearing is accomplished as follows:

- a. Remove rear hood, rear side panel, and bottom cover. See paragraph 5-18.
- b. Move pen arm until it is opposite access slot.
- c. Using Phillips Pozidrive screwdriver, turn bearing adjusting screw until a slight amount of clearance is detectable between the five ball bearing rollers and track rod.
- d. Reassemble.

**CAUTION** Do not overtighten this adjustment. This could result in bearing damage or failure.

5-86. X-AXIS DRIVE TRAIN BEARING REPLACEMENT

5-87. To replace any of the X-axis drive bearings, the X-axis drive cable must be partially or completely removed, depending on which bearing is affected. See Figure 5-23.

5-88. PULLEY BEARING REPLACEMENT. To replace either pulley bearing, proceed as follows:

- a. Remove rear hood and platen. See paragraph 5-18.
- b. Move pen carriage to its extreme position away from affected pulley.
- c. Apply masking tape to remaining pulley and drive sheave so as to prevent cable from slipping off when tension is removed.
- d. Remove bottom cover. See paragraph 5-18.
- e. While holding pulley nut on bottom side of recorder, remove No. 6-32 screw mounting pulley. Remove pulley and its mounting stud.

f. Press out defective bearing. Replace with new bearing, Part No. 1410-0215.

g. Reassemble, making sure pulley is reinstalled with flat side up, as is other pulley.

5-89. DRIVE SHEAVE BEARING REPLACEMENT. To replace, proceed as follows:

- a. Remove rear hood and platen. See paragraph 5-18.
- b. Remove X-axis drive cable.
- c. Remove retaining ring and slip sheave/gear assembly upwards and off stud.
- d. Separate gear from sheave by removing 2 No. 2-56 flat head mounting screws with a Phillips screwdriver.
- e. Push bearings (2) out bottom of sheave and replace with new bearing(s), Part No. 1410-0277.
- f. Restring X-axis. See paragraph 5-44.
- g. Reassemble.

5-90. BELT PULLEY BEARING REPLACEMENT. Replace as follows:

- a. Remove rear hood, platen, and bottom cover. See paragraph 5-18.
- b. Loosen two motor clamping screws (Figure 5-22). Rotate motor until belt is as loose as possible.

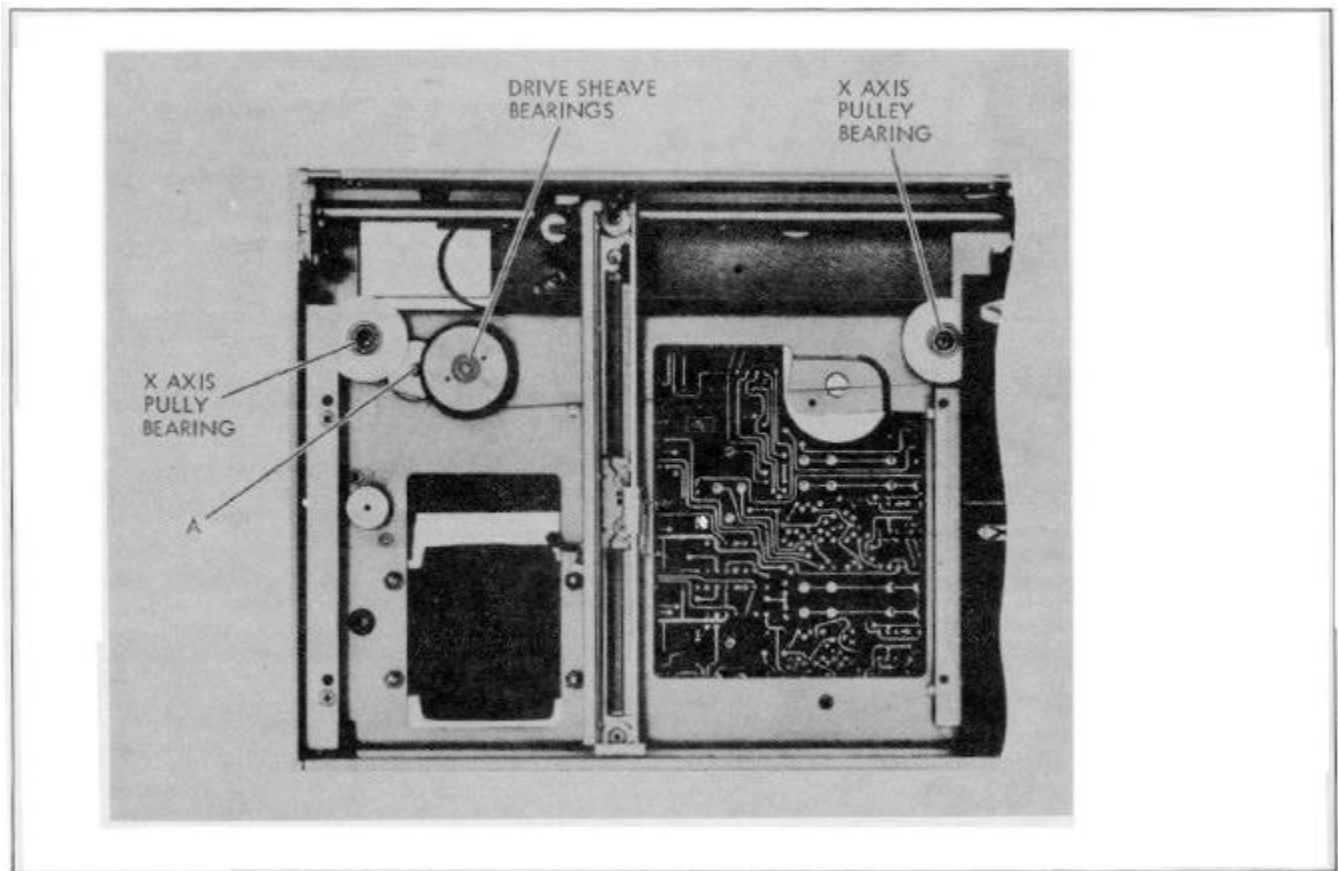

FIGURE 5-23. X-AXIS GEAR TRAIN BEARINGS

c. Remove two clamps holding pulley housing. Slip drive belt off pulley and pull assembly (A) out of its hold from bottom. See Figure 5-23.

d. Remove retaining ring from belt pulley shaft. Slide shaft out of housing.

e. Remove defective bearing(s) and replace with new bearing, Part No. 1410-0277.

f. Reinstall pulley. Adjust belt tension. See paragraph 5-76.

g. Reassemble.

#### 5-91. ELECTRICAL ADJUSTMENTS

#### 5-92. GAIN ADJUSTMENT

5-93. The gain potentiometers are labeled GAIN on the control panel and are adjustable with a screwdriver. If gain in X or Y channel is insufficient (poor retrace) adjust as follows:

a. Connect low frequency Function Generator to X and Y input terminals. Set up for triangular output wave of 500 mV pk/pk at 0.1 Hz.

b. Set X RANGE switch to 100 mV/in. (40 mV/cm), Y RANGE switch to 1V/in. (0.4V/cm).

c. Turn on recorder.

d. Adjust R237 until minimum retrace error exists.

e. Pen speed should not exceed 1 in./sec (0.4 cm/sec).

f. Similarly, set Y RANGE switch to 100 mV/in. (40 mV/cm), X RANGE switch to 1V/in. (0.4V/cm).

g. Adjust R137 for optimum retrace at 1 in./sec (0.4 cm/sec).

#### 5-94. CALIBRATION ADJUSTMENT

5-95. If recalibration adjustment is required to accommodate various graph papers, etc., perform the following procedure:

a. Connect DC Standard to X input terminals.

b. Set RANGE switch to 100 mV/in. (40 mV/cm).

c. Adjust ZERO controls to position pen exactly at zero.

d. Apply 1.0 Vdc (1.25V) signal to X input terminals.

e. Adjust R226 to position pen to full scale.

- f. Remove signal from X input terminals.
- g. Apply 0.7 Vdc (0.9 Vdc) to Y input terminals.
- h. Adjust R126 to position pen to full scale.
- i. In the event full scale cannot be reached by using calibration controls, check electronic reference for output of 9.0 volts  $\pm 5\%$ .

#### 5-96. PHASE SHIFT ADJUSTMENT

5-97. Assuming both X and Y axes have been adjusted by means of the retrace curves described in paragraph 5-91, the attenuator switches may be set to identical values in both X and Y to produce a straight line of 45 degree angle. If the retrace test made on X and Y demonstrates zero trace, the gap which appears in the 45 degree retrace line will be due to a phase difference or time lag between the two recording axes. Phase adjust is accomplished by adjusting R114. Access to R114 is obtained by removing bottom cover. See paragraph 5-18 and Figure 5-24.

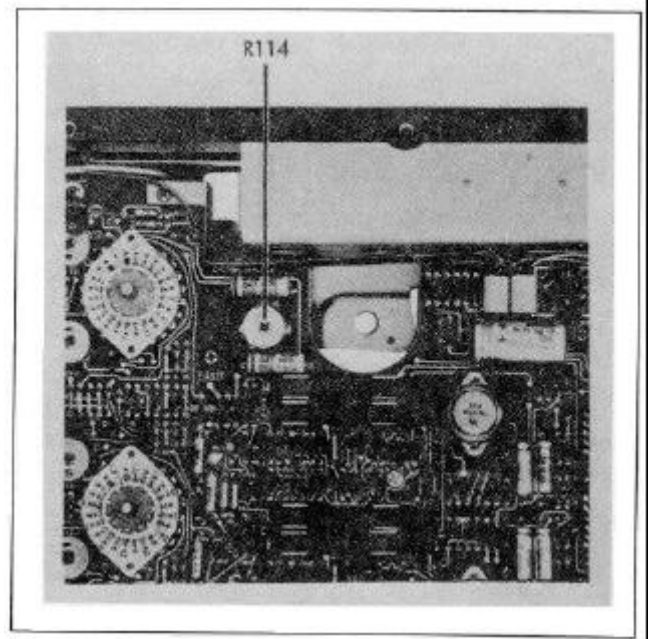

FIGURE 5-24. CIRCUIT BOARD ADJUSTMENT



**SECTION VI****PARTS LIST****6-1. INTRODUCTION**

6-2. This section contains complete information on parts list presented in an alphanumerical and numerical order. The procedure for ordering replacement parts is also contained in this section.

**6-3. PARTS LIST****6-4. ALPHANUMERICAL TABLE**

6-5. Table 6-1 lists parts in alphanumerical order by schematic circuit symbols, H-P number, quantity, five digit manufacturer's code, and manufacturer's part number.

**6-6. MISCELLANEOUS PARTS**

6-7. Table 6-2 lists miscellaneous items not related to those parts in Table 6-1. They will be listed by part number, description, and manufacturer.

**6-8. RECOMMENDED SPARES**

6-9. Table 6-3 lists all components with mortality experience. Recommended quantities to stock for maintaining the instrument for a one-year period are specified in the quantity column.

**6-10. CODE LIST OF MANUFACTURERS**

6-11. Table 6-4 lists the five-digit code number assigned to a specific manufacturer. This table is a cross-reference to Table 6-1 in that the five-digit number listed in Table 6-1 is identified by name in this table.

**6-12. ILLUSTRATED PARTS BREAKDOWN.**

6-13. Additional parts information is included to identify other subassemblies. This information is presented as a parts breakdown illustration with an accompanying legend. See Figures 6-1 and 6-2.

TABLE 6-1. PARTS LIST

Reference Designation	HP Part Number	Qty	Description	Mfr Code	Mfr Part Number
A1			X-Y RECORDER		
B101	5080-3696	1	Y-AXIS SERVO MOTOR	28480	5080-3696
B201	5080-3695	1	X-AXIS SERVO MOTOR	28480	5080-3695
C101	0160-0819	4	C:FXD MY 0.047 UF 10% 600VDCW	14655	WMF-6S47
C102	0160-0819		C:FXD MY 0.047 UF 10% 600VDCW	14655	WMF-6S47
C103	0180-0291	10	C:FXD ELECT 1.0 UF 10% 35VDCW	56289	150D105X9035A2-DYS
C104	0180-0291		C:FXD ELECT 1.0 UF 10% 35VDCW	56289	150D105X9035A2-DYS
C105	0180-0291		C:FXD ELECT 1.0 UF 10% 35VDCW	56289	150D105X9035A2-DYS
C106	0150-0121	2	C:FXD CER 0.1 UF +80-20% 50VDCW	56289	5C50BIS-CML
C107			NOT USED		
C108	0180-0291		C:FXD ELECT 1.0 UF 10% 35VDCW	56289	150D105X9035A2-DYS
C109	0160-0161	4	C:FXD MY 0.01 UF 10% 200VDCW	56289	192P10392-PTS
C110	0160-0161		C:FXD MY 0.01 UF 10% 200VDCW	56289	192P10392-PTS
C111			NOT USED		
C112	0180-0374	6	C:FXD TANT .10 UF 10% 20VDCW	56289	150D106X9020B2-DYS
C113	0180-0374		C:FXD TANT .10 UF 10% 20VDCW	56289	150D106X9020B2-DYS
C114	0180-0137	4	C:FXD ELECT 100 UF 20% 10VDCW	56289	150D107X0010R2-DYS
C115	0180-0137		C:FXD ELECT 100 UF 20% 10VDCW	56289	150D107X0010R2-DYS
C116	0160-0137	4	C:FXD CER 0.33 UF 20% 25VDCW	56289	5C10A7 CML
C117	0160-0818	6	C:FXD CER 0.02 UF 20% 100VDCW	56289	C023B101H203MS27-CDH
C118	0180-0374		C:FXD TANT .10 UF 10% 20VDCW	56289	150D106X9020B2-DYS
C119	0160-0818		C:FXD CER 0.02 UF 20% 100VDCW	56289	C023B101H203MS27-CDH
C120	0160-0818		C:FXD CER 0.02 UF 20% 100VDCW	56289	C023B101H203MS27-CDH
C121	0160-0174	2	C:FXD CER 0.47 UF + 80-20% 25VDCW	56289	5C11B7S-CML
C122	0160-0137		C:FXD CER 0.33 UF 20% 25VDCW	56289	5C10A7 CML
C123	0180-0291		C:FXD ELECT 1.0 UF 10% 35VDCW	56289	150D105X9035A2-DYS
C124	0160-2105	3	C:FXD CER 0.001 UF +100-0% 1000VDCW	72982	8015V-102P
C125	0180-0094	4	C:FXD ELECT 100 UF + 75-10% 25VDCW	56289	30D107G025DD2-DSM
C126	0180-0094		C:FXD ELECT 100 UF + 75-10% 25VDCW	56289	30D107G025DD2-DSM
C201	0160-0819		C:FXD MY 0.047 UF 10% 600VDCW	14655	WMF-6S47
C202	0160-0819		C:FXD MY 0.047 UF 10% 600VDCW	14655	WMF-6S47
C203	0180-0291		C:FXD ELECT 1.0 UF 10% 35VDCW	56289	150D105X9035A2-DYS
C204	0180-0291		C:FXD ELECT 1.0 UF 10% 35VDCW	56289	150D105X9035A2-DYS
C205	0180-0291		C:FXD ELECT 1.0 UF 10% 35VDCW	56289	150D105X9035A2-DYS
C206	0150-0121		C:FXD CER 0.1 UF +80-20% 50VDCW	56289	5C50BIS-CML
C207			NOT USED		
C208	0180-0291		C:FXD ELECT 1.0 UF 10% 35VDCW	56289	150D105X9035A2-DYS
C209	0160-0161		C:FXD MY 0.01 UF 10% 200VDCW	56289	192P10392-PTS
C210	0160-0161		C:FXD MY 0.01 UF 10% 200VDCW	56289	192P10392-PTS
C211			NOT USED		
C212	0180-0374		C:FXD TANT .10 UF 10% 20VDCW	56289	150D106X9020B2-DYS
C213	0180-0374		C:FXD TANT .10 UF 10% 20VDCW	56289	150D106X9020B2-DYS
C214	0180-0137		C:FXD ELECT 100 UF 20% 10VDCW	56289	150D107X0010R2-DYS
C215	0180-0137		C:FXD ELECT 100 UF 20% 10VDCW	56289	150D107X0010R2-DYS
C216	0160-0137		C:FXD CER 0.33 UF 20% 25VDCW	56289	5C10A7 CML
C217	0160-0818		C:FXD CER 0.02 UF 20% 100VDCW	56289	C023B101H203MS27-CDH
C218	0180-0374		C:FXD TANT .10 UF 10% 20VDCW	56289	150D106X9020B2-DYS
C219	0160-0818		C:FXD CER 0.02 UF 20% 100VDCW	56289	C023B101H203MS27-CDH
C220	0160-0818		C:FXD CER 0.02 UF 20% 100VDCW	56289	C023B101H203MS27-CDH
C221	0160-0174		C:FXD CER 0.47 UF + 80-20% 25VDCW	56289	5C11B7S-CML
C222	0160-0137		C:FXD CER 0.33 UF 20% 25VDCW	56289	5C10A7 CML
C223	0180-0291		C:FXD ELECT 1.0 UF 10% 35VDCW	56289	150D105X9035A2-DYS
C224	0160-2105		C:FXD CER 0.001 UF + 100-0% 1000VDCW	72982	801-Z5V-102P
C225	0180-0094		C:FXD ELECT 100 UF + 75-10% 25VDCW	56289	30D107G025DD2-DSM
C226	0180-0094		C:FXD ELECT 100 UF + 75-10% 25VDCW	56289	30D107G025DD2-DSM
C301	0160-2074	2	C:FXD POLY 0.22 UF 1% 100VDCW	14752	410B
C302	0160-2074		C:FXD POLY 0.22 UF 1% 100VDCW	14752	410B
C402	0180-1984	1	C:FXD AL ELECT 350 UF + 75-10% 50VDCW	56289	34D357G050HJ2-DSB
C501	0150-0119	2	C:FXD CER 2X.01 μF ±20% 250WVAC	28480	0150-0119
C502	0150-0119	2	C:FXD CER 2X.01 μF ±20% 250WVAC	28480	0150-0119
CR101	1901-0025	6	DIODE:SILICON 100MA/1V	07263	FD 2387
CR102	1901-0025		DIODE:SILICON 100MA/1V	07263	FD 2387
CR103	1901-0025		DIODE:SILICON 100MA/1V	07263	FD 2387
CR104	1902-0034	2	DIODE:5.76V 10%	28480	1902-0034
CR105	1901-0022	2	DIODE:SILICON 0.56V AT 1 MA	28480	1901-0022
CR106	1901-0191	19	DIODE:SILICON 0.75A 100PIV	04713	SR1358-2
CR107	1901-0191		DIODE:SILICON 0.75A 100PIV	04713	SR1358-2
CR108	1901-0191		DIODE:SILICON 0.75A 100PIV	04713	SR1358-2
CR109	1901-0191		DIODE:SILICON 0.75A 100PIV	04713	SR1358-2
CR110	1901-0191		DIODE:SILICON 0.75A 100PIV	04713	SR1358-2
CR111	1902-0786	4	DIODE:T.C. REFERENCE JEDEC TYPE	04713	1N937
CR112	1902-0202	4	DIODE:BREAKDOWN:15.0V 5% 1W	28480	1906-0202
CR113	1902-0786		DIODE:REFERENCE JEDEC TYPE	04713	1N937
CR114	1902-0202		DIODE BREAKDOWN:15.0V 5% 1W	28480	1901-0202
CR115	1901-0191		DIODE:SILICON 0.75A 100PIV	04713	SR1358-2

See introduction to this section for ordering information

TABLE 6-1. PARTS LIST (Continued)

Reference Designation	HP Part Number	Qty	Description	Mfr Code	Mfr Part Number
CR501	1901-0470	4	DIODE:SILICON 0.75A 1000PIV	28480	1901-0470
CR502	1901-0470		DIODE:SILICON 0.75A 1000PIV	28480	1901-0470
CR503	1901-0470		DIODE:SILICON 0.75A 1000PIV	28480	1901-0470
CR504	1901-0470		DIODE:SILICON 0.75A 1000PIV	28480	1901-0470
CR116	1901-0191		DIODE:SILICON 0.75A 100PIV	04713	SR1358-2
CR117	1901-0191		DIODE:SILICON 0.75A 100PIV	04713	SR1358-2
CR118	1901-0191		DIODE:SILICON 0.75A 100PIV	04713	SR1358-2
CR201	1901-0025		DIODE:SILICON 100MA/1V	07263	FD 2387
CR202	1901-0025		DIODE:SILICON 100MA/1V	07263	FD 2387
CR203	1901-0025		DIODE:SILICON 100MA/1V	07263	FD 2387
CR204	1901-0034		DIODE:5.76V 10%	28480	1902-0034
CR205	1901-0022		DIODE:SILICON 0.56V AT 1 MA	28480	1901-0022
CR206	1901-0191		DIODE:SILICON 0.75A 100PIV	04713	SR1358-2
CR207	1901-0191		DIODE:SILICON 0.75A 100PIV	04713	SR1358-2
CR208	1901-0191		DIODE:SILICON 0.75A 100PIV	04713	SR1358-2
CR209	1901-0191		DIODE:SILICON 0.75A 100PIV	04713	SR1358-2
CR210	1901-0191		DIODE:SILICON 0.75A 100PIV	04713	SR1358-2
CR211	1902-0786		DIODE:T.C. REFERENCE JEDEC TYPE	04713	1N937
CR212	1902-0202		DIODEBREAKDOWN:15.0V 5% 1W	28480	1902-0202
CR213	1902-0786		DIODE:T.C.REFERENCE JEDEC TYPE	04713	1N937
CR214	1902-0202		DIODE BREAKDOWN:15.0V 5% 1W	28480	1902-0202
CR215	1901-0191		DIODE:SILICON 0.75A 100PIV	04713	SR1358-2
CR216	1901-0191		DIODE:SILICON 0.75A 100PIV	04713	SR1358-2
CR217	1901-0191		DIODE:SILICON 0.75A 100PIV	04713	SR1358-2
CR218	1901-0191		DIODE:SILICON 0.75A 100PIV	04713	SR1358-2
CR301	1901-0159	2	DIODE:SILICON 0.75A 400PIV	04713	SR1358-4
CR302	1901-0159		DIODE:SILICON 0.75A 400PIV	04713	SR1358-4
CR401	1901-0191		DIODE:SILICON 0.75 A 100PIV	04713	SR1358-2
CR501	1901-0487	2	DIODE:SILICON 1500 PIV	28480	1901-0487
CR402	1901-0033		DIODE:SILICON	28480	1901-0033
CR502	1901-0487		DIODE:SILICON 1500 PIV	28480	1901-0487
DS301	2140-0047	4	LAMP:NEON GLOW 0.8 MILLIAMPS	08806	A1C
DS302	2140-0047		LAMP:NEON GLOW 0.8 MILLIAMPS	08806	A1C
DS303	2140-0047		LAMP:NEON GLOW 0.8 MILLIAMPS	08806	A1C
DS304	2140-0047		LAMP:NEON GLOW 0.8 MILLIAMPS	08806	A1C
DS601	1450-0495	1	LIGHT INDICATOR, WHITE PLASTIC LENS	08717	895-W-C2A-22K
F601	2110-0065	1	FUSE:0.375A 250V (FOR 230V LINE)	75915	312.375
F601	2110-0063	1	FUSE:0.75A 250V (FOR 115V LINE)	75915	312.750
F601	1400-0084	1	FUSEHOLDER:EXTRACTOR POST TYPE	75915	342014
J101	1510-0008	4	BINDING POST:RED	28480	1510-0008
J102	1510-0008		BINDING POST:RED	28480	1510-0008
J103	1910-0009	1			
J201	1510-0008		BINDING POST:RED	28480	1510-0008
J202	1510-0008		BINDING POST:RED	28480	1510-0008
J203	1510-0009	1	BINDING POST:BLACK	28480	1510-0009
J601	8120-1378	1	CABLE ASSY:AC POWER CORD	70903	KH-7081
J602	1251-0292	1	CONNECTOR:FEMALE 24 PIN	28480	1251-0292
J602	1251-0293	1	CONNECTOR:24 CONTACT	28480	1251-0293
K401	07035-81640	1	RELAY	28480	07035-81640
P601	1251-2357	1	SOCKET:3-PIN MALE POWER RECEPTACLE	82389	EAC-301
Q101	1855-0067	4	TSTR:FET SI N-CHANNEL	28480	1855-0067
Q102	1855-0067		TSTR:FET SI N-CHANNEL	28480	1855-0067
Q103	1854-0201	4	TSTR:SI NPN	80131	2N3391A
Q104	1853-0020	4	TSTR:SI PNP (SELECTED FROM 2N3702)	28480	1853-0020
Q105	1854-0202	3	TSTR:SI NPN	80131	2N3390
Q106	1854-0201		TSTR:SI NPN	80131	2N3391A
Q107	1854-0202		TSTR:SI NPN	80131	2N3390
Q108	1853-0020		TSTR:SI PNP (SELECTED FROM 2N3702)	28480	1853-0020
Q109	1854-002	2	TSTR:SI NPN	07263	S17843
Q110	5060-4502	2	TRANSISTOR	28480	5060-4502
Q201	1855-0067		TSTR:FET SI N-CHANNEL	28480	1855-0067
Q202	1855-0067		TSTR:FET SI N-CHANNEL	28480	1855-0067
Q203	1854-0201		TSTR:SI NPN	80131	2N3391A
Q204	1853-0020		TSTR:SI PNP (SELECTED FROM 2N3702)	28480	1853-0020
Q205	1854-0202		TSTR:SI NPN	80131	2N3390
Q206	1854-0201		TSTR:SI NPN	80131	2N3391A
Q207	1854-0020	1	TSTR:SI NPN	28480	1854-0020
Q208	1853-0020		TSTR:SI PNP (SELECTED FROM 2N3702)	28480	1853-0020
Q209	1854-0022		TSTR:SI NPN	07263	S17843
Q210	5060-4502		TRANSISTOR	28480	5060-4502
R101	0698-5527	4	R:FXD FLM 900K OHM 0.1% 1/4W	28480	0698-5527
R102	0698-4342	6	R:FXD FLM 90K OHM 0.1% 1/8W	28480	0698-4342
R103	0698-5454	2	R:FXD FLM 9K OHM 0.1% 1/8W	28480	0698-5454
R104	0698-5453	2	R:FXD FLM 900 OHM 0.1% 1/8W	28480	0698-5453
R105	0698-4343	2	R:FXD FLM 100 OHM 0.1% 1/8W	28480	0698-4343
R106	0698-5527		R:FXD FLM 900K OHM 0.1% 1/4W	28480	0698-5527
R107	0698-4342		R:FXD FLM 90K OHM 0.1% 1/8W	28480	0698-4342
R108	2100-2682	4	R:VAR WW 10K OHM 10% LIN 2W	28480	2100-2682
R109	0684-1021	6	R:FXD COMP 1000 OHM 10% 1/4W	01121	CB 1021
R110	0698-3229	4	R:FXD FLM 1K OHM 1% 1/8W	28480	0698-3229

See introduction to this section for ordering information

TABLE 6-1. PARTS LIST (Continued)

Reference Designation	HP Part Number	Qty	Description	Mfr Code	Mfr Part Number
R111	0698-4342		R:FXD FLM 90K OHM 0.1% 1/8W	28480	0698-4342
R112	0757-0201	2	R:FXD FLM 6.81K OHM 1% 1/8W	28480	0757-0201
R113	0757-0433	2	R:FXD MET FLM 3.32K OHM 1% 1/8W	28480	0757-0433
R114	2100-0396	2	R:VAR WW 10K OHM LIN 20% 1W	28480	2100-0396
R115	0684-1531	4	R:FXD COMP 15K OHM 10% 1/4W	01121	CB 1531
R116	0684-1531		R:FXD COMP 15K OHM 10% 1/4W	01121	CB 1531
R117	0683-1045	4	R:FXD COMP 100K OHMS 5% 1/4W	01121	CB 1045
R118	0683-1045		R:FXD COMP 100K OHMS 5% 1/4W	01121	CB 1045
R119	0698-3229		R:FXD FLM 1K OHM 1% 1/8W	28480	0698-3229
R120	0698-4160	2	R:FXD FLM 866K OHM 1% 1/4W	28480	0698-4160
R121	0698-4160		R:FXD FLM 866K OHM 1% 1/4W	28480	0698-4160
R122	0684-1041	4	R:FXD COMP 100K OHM 10% 1/4W	01121	CB 1041
R123	2100-2682		R:VAR WW 10K OHM 10% LIN 2W	28480	2100-2682
R124	07035-80750	1	SLIDEWIRE ASSEMBLY 3.5K OHM	28480	07035-80750
R124	5080-7706	1	WIPER-Y-AXIS	28480	5080-7706
R125	0698-5154	1	R:FXD FLM 866 OHM 1% 1/4W	28480	0698-5154
R126	2100-2289	2	R:VAR WW 1K OHM ± 2% 2W	28480	2100-2289
R127	0683-1055	4	R:FXD COMP 1 MEGOHM 5% 1/4W	01121	CB 1055
R128	0684-4731	6	R:FXD COMP 47K OHM 10% 1/4W	01121	CB 4731
R129	0683-2025	4	R:FXD COMP 2000 OHM 5% 1/4W	01121	CB 2025
R130	0683-2025		R:FXD COMP 2000 OHM 5% 1/4W	01121	CB 2025
R131	0684-2731	2	R:FXD COMP 27K OHM 10% 1/4W	01121	CB 2731
R132	0684-4731		R:FXD COMP 47K OHM 10% 1/4W	01121	CB 4731
R133	0683-1055		R:FXD COMP 1 MEGOHM 5% 1/4W	01121	CB 1055
R134	0684-1541	4	R:FXD COMP 150K OHM 10% 1/4W	01121	CB 1541
R135	0684-1541		R:FXD COMP 150K OHM 10% 1/4W	01121	CB 1541
R136	0699-0001	2	R:FXD COMP 2.7 OHM 10% 1/2W	01121	EB 27G1
R137	2100-1729	2	R:VAR WW 10 OHM 20% LIN 2W	28480	2100-1729
R138	0684-4741	4	R:FXD COMP 470K OHM 10% 1/4W	01121	CB 4741
R139	0684-1031	2	R:FXD COMP 10K OHM 10% 1/4W	01121	CB 1031
R140	0684-4741		R:FXD COMP 470K OHM 10% 1/4W	01121	CB 4741
R141	0684-1831	2	R:FXD COMP 18K OHM 10% 1/4W	01121	CB 1831
R142	0684-3311	4	R:FXD COMP 33K OHM 10% 1/4W	01121	CB 3331
R143	0683-3945	2	R:FXD COMP 390K OHM 5% 1/4W	01121	CB 3945
R144	0684-4731		R:FXD COMP 47K OHM 10% 1/4W	01121	CB 4731
R145	0683-2225	2	R:FXD COMP 2.2K OHM 5% 1/4W	01121	CB 2225
R147	0684-1841	2	R:FXD COMP 180K OHM 10% 1/4W	01121	CB 1841
R148	0684-1041		R:FXD COMP 100K OHM 10% 1/4W	01121	CB 1041
R149	0684-1021		R:FXD COMP 1000 OHM 10% 1/4W	01121	CB 1021
R150	0684-3331		R:FXD COMP 33K OHM 10% 1/4W	01121	CB 3331
R151	0684-1021		R:FXD COMP 1000 OHM 10% 1/4W	01121	CB 1021
R152	0684-4711	2	R:FXD COMP 470 OHM 10% 1/4W	01121	CB 4711
R153	0684-1521	2	R:FXD COMP 1500 OHM 10% 1/4W	01121	CB 1521
R154	0683-4725		R:FXD COMP 4700 OHM5% 1/4W	01121	CB 4725
R155	0813-0046	2	R:FXD WW 1 OHM 10% 3W	28480	0813-0046
R156	0683-6215	4	R:FXP COMP 620 OHM 5% 1/4W	01121	CB 6215
R157	0761-0049	4	R:FXD MET OX 200 OHM 5% 1W	28480	0761-0049
R158	0683-6215		R:FXD COMP 620 OHM 5% 1/4W	01121	CB 6215
R159	0761-0049		R:FXD MET OX 200 OHM 5% 1W	28480	0761-0049
R201	0698-5527		R:FXD FLM 900K OHM 0.1% 1/4W	28480	0698-5527
R202	0698-4342		R:FXD FLM 90K OHM 0.1% 1/8W	28480	0698-4342
R203	0698-5454		R:FXD FLM 9K OHM 0.1% 1/8W	28480	0698-5454
R204	0698-5453		R:FXD FLM 900 OHM 0.1% 1/8W	28480	0698-5453
R205	0698-4343		R:FXD FLM 100 OHM 0.1% 1/8W	28480	0698-4343
R206	0691-5527		R:FXD FLM 900K OHM 0.1% 1/8W	28480	0698-5527
R207	0698-4342		R:FXD FLM 90K OHM 0.1% 1/8W	28480	0698-4342
R208	2100-2682		R:VAR WW 10K OHM 10% LIN 2W	28480	2100-2682
R209	0684-1021		R:FXD COMP 1000 OHM 10% 1/4W	01121	CB 1021
R210	0698-3229		R:FXD FLM 1K OHM 1% 1/8W	28480	0698-3229
R211	0698-4342		R:FXD FLM 90K OHM 0.1% 1/8W	28480	0698-4342
R212	0757-0201		R:FXD FLM 6.81K OHM 1% 1/8W	28480	0757-0201
R213	0757-0433		R:FXD MET 3.32K OHM 1% 1/8W	28480	0757-0433
R214	0683-4725	1	R:FXD COMP 4700 OHM 5% 1/4W	28480	2100-0396
R215	0684-1531		R:FXD COMP 15K OHM 10% 1/4W	01121	CB 1531
R216	0684-1531		R:FXD COMP 15K OHM 10% 1/4W	01121	CB 1531
R217	0683-1045		R:FXD COMP 100K OHM 5% 1/4W	01121	CB 1045
R218	0683-1045		R:FXD COMP 100K OHM 5% 1/4W	01121	CB 1045
R219	0698-3229		R:FXD FLM 1K OHM 1% 1/8W	28480	0698-3229
R220	0698-4159	2	R:FXD FLM 604K OHM 1% 1/4W	28480	0698-4159
R221	0698-4159		R:FXD FLM 604K OHM 1% 1/4W	28480	0698-4159

See introduction to this section for ordering information

TABLE 6-1. PARTS LIST (Continued)

Reference Designation	HP Part Number	Qty	Description	Mfr Code	Mfr Part Number
R222	0684-1041		R:FXD COMP 100K OHM 10% 1/4W	01121	CB 1041
R223	2100-2682		R:VAR WW 10K OHM 10% LIN 2W	28480	2100-2682
R224	07035-80730	1	SLIDEWIRE ASSY:5K OHM	28480	07035-80730
R224	5060-4570	1	WIPER X-AXIS	28480	5060-4570
R225	0757-0427	1	R:FXD MET FLM 1.5K OHM 1% 1/8W	28480	0757-0427
R226	2100-2289		R:VAR 1K ± 20% 2W	28480	2100-2289
R227	0683-1055		R:FXD COMP 1 MEGOHM 5% 1/4W	01121	CB 1055
R228	0683-4731		R:FXD COMP 47K OHM 10% 1/4W	01121	CB 4731
R229	0683-2025		R:FXD COMP 2000 OHM 5% 1/4W	01121	CB 2025
R230	0683-2025		R:FXD COMP 2000 OHM 5% 1/4W	01121	CB 2025
R231	0684-2731		R:FXD COMP 27K OHM 10% 1/4W	01121	CB 2731
R232	0684-4731		R:FXD COMP 47K OHM 10% 1/4W	01121	CB 4731
R233	0683-1055		R:FXD COMP 1 MEGOHM 5% 1/4W	01121	CB 1055
R234	0684-1541		R:FXD COMP 150K OHM 10% 1/4W	01121	CB 1541
R235	0684-1541		R:FXD COMP 150K OHM 10% 1/4W	01121	CB 1541
R236	0699-0001		R:FXD COMP 2.7 OHM 10% 1/2W	01121	EB 27G1
R237	2100-1729		R:VAR WW 10 OHM 20% LIN 2W	28480	2100-1729
R238	0684-4741		R:FXD COMP 470K OHM 10% 1/4W	01121	CB 4741
R239	0684-1031		R:FXD COMP 10K OHM 10% 1/4W	01121	CB 1031
R240	0684-4741		R:FXD COMP 470K OHM 10% 1/4W	01121	CB 4741
R241	0684-1831		R:FXD COMP 18K OHM10% 1/4W	01121	CB 1831
R242	0684-3331		R:FXD COMP 33K OHM 10% 1/4W	01121	CB 3331
R243	0683-3945		R:FXD COMP 390K OHM 5% 1/4W	01121	CB 3945
R244	0684-4731		R:FXD COMP 47K OHM 10% 1/4W	01121	CB 4731
R245	0683-2225		R:FXD COMP 2.2K OHM 5% 1/4W	01121	CB 2225
R246	0684-6811		R:FXD COMP 680 OHM 10% 1/4W	01121	CB 6811
R247	0684-1841		R:FXD COMP 180K OHM 10% 1/4W	01121	CB 1841
R248	0684-1041		R:FXD COMP 100K OHM 10% 1/4W	01121	CB 1041
R249	0684-1021		R:FXD COMP 1000 OHM 10% 1/4W	01121	CB 1021
R250	0684-3331		R:FXD COMP 33K OHM 10% 1/4W	01121	CB 3331
R251	0684-1021		R:FXD COMP 1000 OHM10%1/4W	01121	CB 1021
R252	0684-4711		R:FXD COMP 470 OHM 10% 1/4W	01121	CB 4711
R253	0684-1521		R:FXD COMP 1500 OHM 10% 1/4W	01121	CB 1521
R254	0683-4725		R:FXD COMP 4700 OHM 5% 1/4W	01121	CB 4725
R255	0813-0046		R:FXD WW 1 OHM 10% 3W	28480	0813-0046
R256	0683-6215		R:FXD COMP 620 OHM 5% 1/4W	01121	CB 6215
R257	0761-0049		R:FXD MET OX 200 OHM 5% 1W	28480	0761-0049
R258	0683-6215		R:FXD COMP 620 OHM 5% 1/4W	01121	CB 6215
R259	0761-0049		R:FXD MET OX 200 OHM 5% 1W	28480	0761-0049
R301	0684-6831	4	R:FXD COMP 68K OHM 10% 1/4W	01121	CB 6831
R302	0684-6831		R:FXD COMP 68K OHM 10% 1/4W	01121	CB 6831
R303	0684-6831		R:FXD COMP 68K OHM 10% 1/4W	01121	CB 6831
R304	0684-6831		R:FXD COMP 68K OHM10% 1/4W	01121	CB 6831
R401	0811-1202	1	R:FXD WW 50 OHM 5% 3W	28480	0811-1202
R501	0683-6845	1	R:FXD 680K ±5% 1/4W	28480	0683-6845
R502	0698-8754	2	R:FXD 10 MEG ±1% 1/4W	28480	0698-8754
R503	0698-8754	2	R:FXD 10 MEG ±1% 1/4W	28480	0698-8754
R601			NOT USED		
R602	2100-1621	1	R:VAR 5K WW 4W	28480	2100-1621
S101	3130-0166	2	SECTION:ROTARY SWITCH	28480	3130-0166
S201	3130-0166		SECTION:ROTARY SWITCH	28480	3130-0166
S401	3101-1702	2	SWITCH:TOGGLE SPDT	18911	8926K124
S501	3101-1702		SWITCH:TOGGLE SPDT	18911	8926K124
S601	3101-2404	1	SWITCH:TOGGLE SPDT	82389	11A-1242
S602	3101-1174	1	SWITCH:TOGGLE SPDT	18911	7511K4
T601	5060-6857		TRANSFORMER ASSEMBLY		
V101	1990-0072	4	PHOTOCONDUCTOR:2-LEAD, T0-5 PACKAGE	28480	1990-0072
V102	1990-0072		PHOTOCONDUCTOR:2-LEAD, T0-5 PACKAGE	28480	1990-0072
V201	1990-0072		PHOTOCONDUCTOR:2-LEAD, T0-5 PACKAGE	28480	1990-0072
V202	1990-0072		PHOTOCONDUCTOR:2-LEAD, T0-5 PACKAGE	28480	1990-0072
R504	0698-3453	2	R:FXD 196K ±1% 1/8W	28480	0698-3453
R505	0698-3453	2	R:FXD 196K ±1% 1/8W	28480	0698-3453

See introduction to this section for ordering information

TABLE 6-2. MISCELLANEOUS PARTS

Circuit Symbol	Part No.	Description	Typical Mfr	Mfr Part No.
MECHANICAL, ELECTRICAL, ETC.				
	1251-0293	Connector, 24-pin (mate for J-602)	Amphenol	57-30240
	1400-0084	Fuse holder	Littlefuse	342004
	17999-06494	Pulley, Drive cable (white plastic)	H-P	17999-06494
	17999-06460	Spring, Cable tension	H-P	17999-06460
	17999-16046	Clamp and Pad Assy (for shipping)	H-P	17999-16046
	4040-0011	Dust Cover (plastic)	Allen Plastic	
	5080-3627	X Axis Stringing Kit	H-P	5080-3627
	1251-0148	Receptacle, Power, Cord	Tower Mfg.	H-1061 I.G.
	1500-0043	Belt, Drive, clutch (mylar)	Kinelogic Corp.	
	5080-3635	Lubricant Slidewire	H-P	5080-3635
	8120-1378	Power cord, 7.5 ft.	Belden	KMS-7041
	5060-0761	Foot, Stacking	H-P	50600761
	0703501660	Bracket		
	8120-039	Spectrastrip (9 conductor)(Y-axis trailing cable)	Spectrastrip	
	1490-0080	Shorting Links (Guard Straps)	H-P	1490-0080
	07035-01020	Panel Control (English)	H-P	07035-01020
	07035-62260	Hood Assembly (Standard)		
	07035-01030	Panel Control (Metric)	H-P	07035-01030
	07035-01000	Panel, Side, RH and LH	H-P	07035-01000
	07004-01860	Panel, front, rear	H-P	07004-01860
	07035-61440	Cable Assembly		
	07035-00511	Cover, Bottom	H-P	07035-00511
	07035-61660	Rear Hood Assy (Standard)	H-P	07035-61660
	07035-61670	Rear Hood Assy (Metric)	H-P	07035-61670
	07035-64270	Hood Assembly (Metric) Option 001		
	07004-60640	Solenoid, Pen lit (Serial Prefix 826 and below require index pointer 07005-00730)	H-P	
	07035-62160	Clutch Assy, X-axis	H-P	07035-62160
	07035-81000	Table, Electrostatic	H-P	07035-81000
	07035-80730	Slidewire, X-axis	H-P	07035-80730
	07035-81020	Shipping Carton	H-P	07035-81020
	09125-20350	Plunger Assembly, solenoid	H-P	
ACCESSORY KIT, PAPER, INK				
	07035-82660	Accessory Kit	H-P	0703-82660
	508-1190	Pen, Disposable, Red	H-P	5081-1990
	5081-1191	Pen, Disposable, Blue	H-P	5081-1191
	5081-1192	Pen, Disposable, Green	H-P	5081-1192
	5081-1193	Pen, Disposable, Black	H-P	5081-1193
	9270-1006	Chart Paper, Standard (heavy)	Gubelman	H-10070/A
	9270-1007	Chart Paper, Standard (light)	Gubelman	L-10070/A
	9270-1023	Chart Paper, Metric (heavy)	Gubelman	
	9270-1027	Chart Paper, Metric (light)	Gubelman	
KNOBS				
	0370-0025	Zero & Vernier Control	H-P	03700025
	0370-0112	Attenuator	H-P	03700112

TABLE 6-3. RECOMMENDED ONE YEAR ISOLATED SPARE PARTS LIST

Circuit Symbol	Part No.	Description	Typical Mfr	Mfr Part No.	RS
B-101	5080-3696	Servo Motor, Y-axis	H-P	5080-3696	1
B-201	5080-3695	Servo Motor, X-axis	H-P	5080-3695	1
C-402	0180-1984	Cap, Elect, 350 $\mu$ f, +75 -10% 50wvdc	Sprague	34D357G050	1
CR-104	1902-0034	Diode, Zener, 5.76v, $\pm$ 10%	TRW	PS18237	1
CR-204					
CR-111					
CR-113	1902-0786	Diode, Zener, 9.0v, $\pm$ 5%	Motorola	IN937	1
CR-211					
CR-213					
CR-112					
CR-114	1902-0202	Diode, Zener, 15v, 5%, 1w	Motorola	SZ11213-191	1
CR-212					
CR-214					
CR-501	1901-0487	Diode, Silicon	Semtech	SS1138	2
CR-502					
DS-301					
DS-302	2140-0047	Lamp, Neon, 1/10w, 0.8ma,	G. E.	A1C	2
DS-303					
DS-304		68K ohms			
DS-304					
DS-601	1450-0495	Indicator Light	Sloan Co.	859-W-(ZA-22K)	
F-601	2110-0063	Fuse, 750 mA	Littlefuse	312.750	5
	2110-0065	Fuse, 375 mA	Littlefuse	312.375	
K-401	07004	Solenoid, Pen Lift	H-P	07004-60650	1
	60650				
	09125	Plunger Assembly, Solenoid	H-P	09125-20350	1
	20350				
Q-101					
Q-102	1855-0067	Transistor, Field Effect	Siliconix Inc.	E-101	2
Q-201					
Q-202					
Q-103					
Q-406	1854-0201	Transistor, NPN Silicon	G. E.	2N3391A	2
Q-203					
Q-206					
Q-104					
Q-108	1853-0020	Transistor, PNP Silicon	Texas Inst.	SM-9143	2
Q-204					
Q-208					
Q-105					
Q-107	1854-0202	Transistor, NPN Silicon	G. E.	2N3390	2
Q-205					
Q-207					
Q-109	1854-0022	Transistor, NPN Silicon	Fairchild		1
Q-209					
Q-110	5060-4502	Transistor Assembly, NPN Silicon	H-P	5060-4502	1
Q-210					

TABLE 6-3. RECOMMENDED ONE YEAR ISOLATED SPARE PARTS LIST (Continued)

Circuit Symbol	Part No.	Description	Typical Mfr	Mfr Part No.	RS
R-124	07035-80750	Resistor, Variable, 3.5K (Slidewire)	H-P	07035-80750	1
R-224	5080-7706	Wiper Assembly, (Y-axis)	H-P	07035-80730	2
	07035-80730	Resistor, Variable, 5K (Slidewire)	H-P		1
R-155 R-255 V-101 V102 V-201 V-202	5060-4570	Wiper Assembly, (X-axis) For serial prefixes below 823, coil and wiper bracket <b>5060-4569</b> , also required.	H-P		2
	0813-0046	Resistor, ww, 1 ohm, ±10%, 3w	Sprague	242E	1
	1990-0072	Photoconductor	H-P	1990-0072	2
	1500-0043	Belt, Drive, Clutch (Mylar)	Kinelogic Corp.		1
	5080-3627	Restranging Kit (X-axis)	H-P	5080-3627	1
	07035-61420	Cable Assembly (Y-axis)	H-P	07035-61420	1
	07035-60460	Trailing Cable (Y-axis)	H-P	8120-1039	1
	07035-62160	Clutch Assembly, X-axis	H-P	07035-62160	1
	5060-6428	Pen Holder	H-P	5060-6428	1

TABLE 6-4. MANUFACTURER'S CODE LIST

MFR NO.	MANUFACTURER'S NAME	ADDRESS	ZIP CODE
01121	Alien Bradley Company	Milwaukee, Wis.	53204
04713	Motorola Semiconductor Products Inc.	Phoenix, Ariz.	85008
07263	Fairchild Camera & Inst. Corp. Semiconductor Div.	Mountain View, Calif.	94040
08806	G. E. Co. Miniature Lamp Dept.	Cleveland, Ohio	44112
14655	Cornell Dubilier Elect, Div. Federal Pacific Elect. Co.	Newark, N. J.	07105
14752	Electro-Cube, Inc.	San Gabriel, Calif.	91776
18911	Cutler-Hammer Inc. Durant Digital Inst.	Milwaukee, Wis.	53201
28480	Hewlett-Packard Company	Palo Alto, Calif.	94304
56289	Sprague Electric Co.	N. Adams, Mass.	01247
70903	Belden Corp.	Chicago, Ill.	60644
72619	Dialight Corp.	Brooklyn, N. Y.	11237
72982	Erie Technological Prod. Inc.	Erie, Pa.	16512
75915	Littlefuse Inc.	Des Plaines, Ill.	60016
80131	Electronic Industries Association	Washington, D. C.	20006
82389	Switchcraft, Inc.	Chicago, Ill.	60630
91418	Radio Materials Co.	Chicago, Ill.	60646



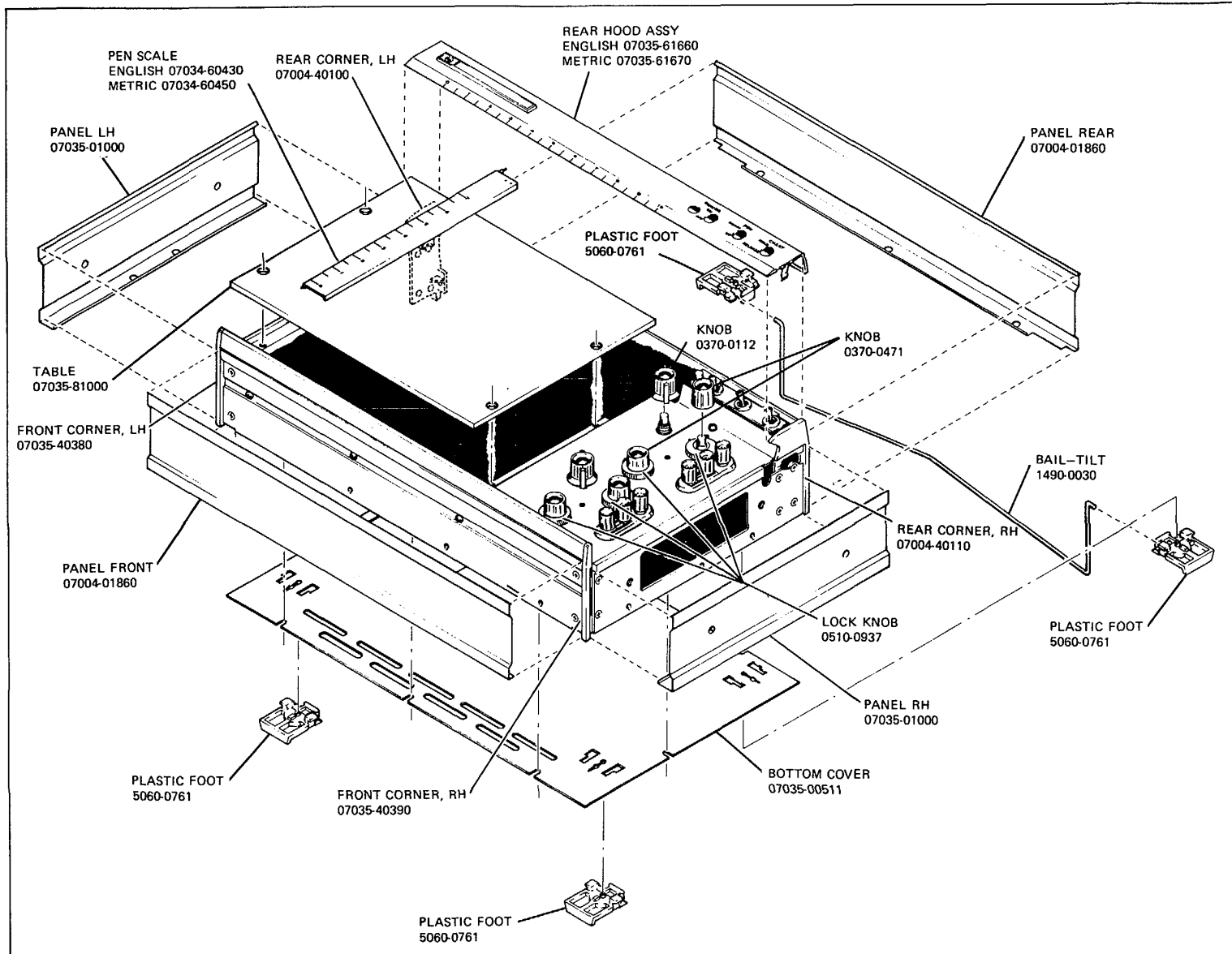

FIGURE 6-1. EXPLODED VIEW-CABINET

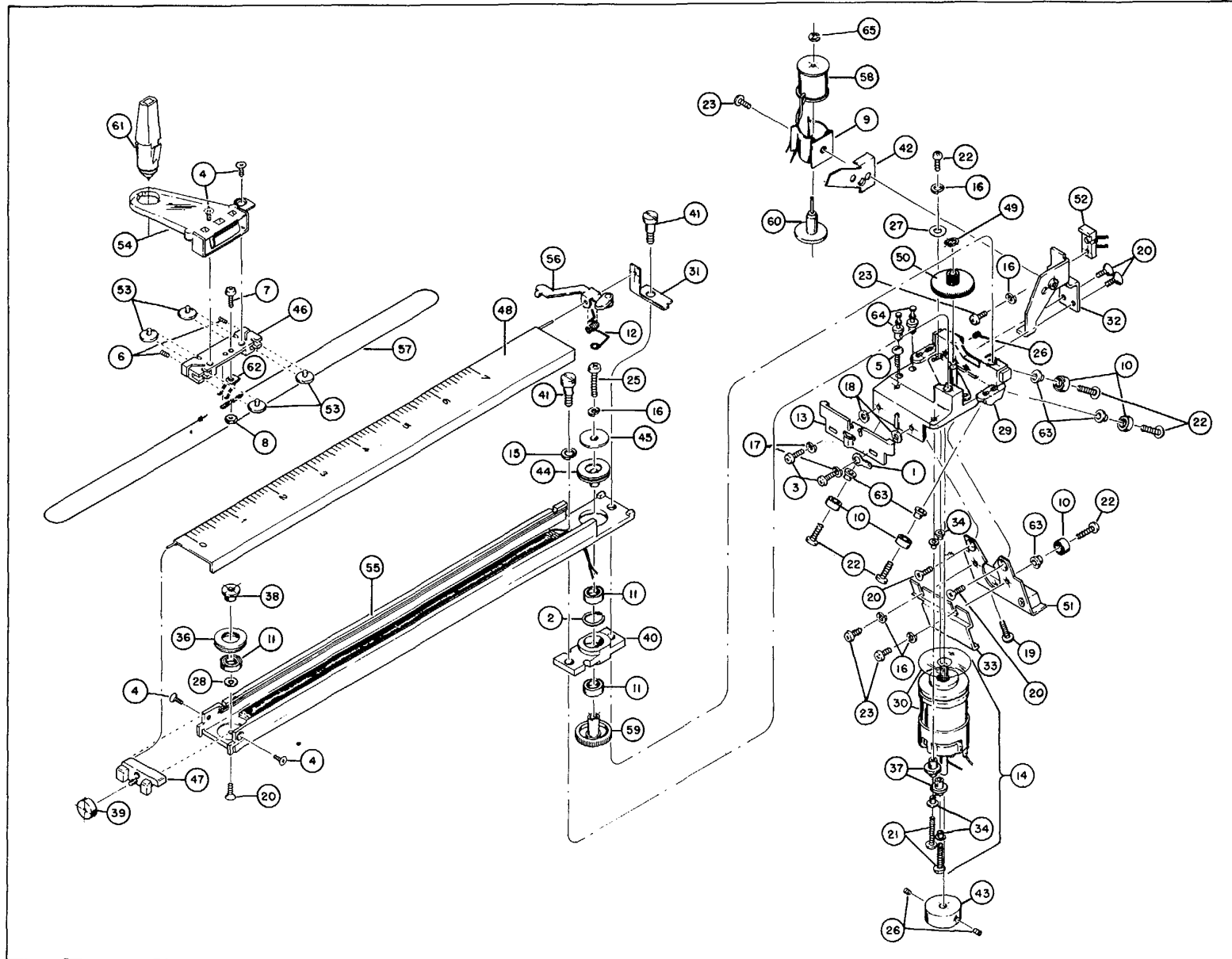

FIGURE 6-2. EXPLODED VIEW-CARRIAGE ARM (SHEET 1 OF 2)

<u>B/N</u>	<u>Part No.</u>	<u>Description</u>	<u>Typical Mfr.</u>
1	0360-0243	Solder Lug, Flat #2	Zierick Mfg. Co.
2	1460-0940	Spring, Retaining	Superior Spring
3	0520-0066	Screw, Machine, 2-56 x 3/16 PH, PD, SS	Schnitzer Alloy
4	0520-0163	Screw, Machine, 2-56 x 3/16 FH, PD, SS	Hewlett-Packard
5	2200-0710	Screw, Machine, 4/40 x 3/8 Truss, Set, Pass, Slot	
6	0570-0142	Screw, Set 2-56 x 1/8 Spline Dr.	Bristol
7	0570-0190	Screw, Machine 0-80 x 1/8 FH, PD, SS	
8	0590-0149	Nut, Hex 0-80 SS	Corland Co.
9	1400-0304	Clip - Component	Augat, Inc.
10	1410-0941	Ball Bearing	New Hampshire
11	1410-0269	Ball Bearing	New Hampshire
12	1460-1201	Spring, Pen Lift	Superior Spring
13	5000-4225	Yoke, Cable	Hewlett-Packard
14	5080-3633	Motor Replacement Kit	Hewlett-Packard
15	2190-0087	Washer, Lock, Helical #8	Eaton Mfg. Co.
16	2190-0108	Washer, Lock, Helical #4	
17	2190-0094	Washer, Lock, Helical #2	
18	3050-0303	Washer, Flat #2	Corland Co.
19	2200-0048	Screw, Machine 4-40 x 3/8 FH, PD, SS	
20	2200-0056	Screw, Machine 4-40 x 3/16 FH, PD, SS	
21	<b>2200-0143</b>	Screw, Machine 4-40 x 3/8 FH, PD, SS	Schnitzer Alloy
22	0570-1103	Screw, Shouldered 4-40 x 3/8	Hewlett-Packard
23	2270-0022	Screw, Machine 4-40 x 3/16 FH, PD, SS	
24	Not used		
25	2270-0049	Screw, Machine 4-40 x 7/16 FH, PD, SS	
26	3030-0169	Screw, Set 4-40 x 1/8 Spline Dr.	Bristol
27	3030-0222	Washer, Flat #4	Western Washer
28	3050-0394	Washer, Flat #4 shim SS	Hewlett-Packard
29	<b>07035-61850</b>	Block, Servo Motor	Hewlett-Packard
30	5080-3696	Servo Motor Y-Axis	Hewlett-Packard
31	07035-00230	Rear Mount, Scale	Hewlett-Packard
32	5060-4569	Bracket-Coil & Wiper	Hewlett-Packard
33	07035-02370	Clamp, Cable	Hewlett-Packard
34	0340-0418	Bushing, Insulation	Nylomatic N5228
35	Not Used		
36	07035-20200	Pulley, Return (Lower)	Hewlett-Packard
37	07035-62420	Cleat, Motor Assembly	Hewlett-Packard
38	07035-20240	Stud, Pulley Return	Hewlett-Packard
39	07035-20280	Wheel, Pen Arm	Hewlett-Packard
40	07035-20330	Mounting Block, Pen Arm	Hewlett-Packard
41	07035-20350	Screw, Shoulder	Hewlett-Packard
42	<b>07005-00730</b>	Pointer, Index (X - Axis)	Hewlett-Packard
43	07035-22020	Flywheel	Hewlett-Packard
44	07035-20310	Pulley, Pen Drive (Upper)	Hewlett-Packard
45	07035-22190	Stop, Pen Block	Hewlett-Packard
46	07035-40370	Carriage Block, Pen	Hewlett-Packard
47	<b>07034-40020</b>	Block, Pen Arm	Hewlett-Packard
48	07034-60430	Pen Scale Assembly - English Scale	Hewlett-Packard
	07034-60450	Pen Scale Assembly - Metric Scale	Hewlett-Packard
49	0510-0724	Ring, Grip	Hewlett-Packard
50	07035-60590	Gear, Pen Drive Assembly	Hewlett-Packard
51	07035-60700	Bearing Adjustment Assembly	Hewlett-Packard
52	<b>5060-4570</b>	<b>Wiper Assembly (Prefix 823 &amp; above)</b>	Hewlett-Packard
	<b>07035-60520</b>	<b>Wiper Conversion Kit (Prefix below 823)</b>	
53	07035-60860	Wheel Assembly, Pen Carriage	Hewlett-Packard
54	5060-6428	Pen Holder Assembly	Hewlett-Packard
55	07035-80750	Pen Arm Assembly	Hewlett-Packard
56	5060-6538	Pen Lift Assembly	Hewlett-Packard
57	07035-61420	Pen Carriage Cable Assembly	Hewlett-Packard
58	07004-60640	Solenoid Assembly (Below serial prefix 826 requires index pointer 07005-00730)	Hewlett-Packard
59	07035-61700	Pen Drive Assembly	Hewlett-Packard
60	09125-20350	Plunger, Solenoid Assembly	Hewlett-Packard
61	<b>5061-1190</b>	<b>Pen, Disposable, Red</b>	<b>HP</b>
	<b>5061-1191</b>	<b>Pen, Disposable, Blue</b>	<b>HP</b>
	<b>5061-1192</b>	<b>Pen, Disposable, Green</b>	<b>HP</b>
	<b>5061-1193</b>	<b>Pen, Disposable, Black</b>	<b>HP</b>
62	5080-7706	Wiper Assembly (Y - Axis)	Hewlett-Packard
63	3050-0710	Washer, .130 ID, .250 OD, .010 THK	Western Washer
64	03060-1626	Terminal, Stud	Hewlett-Packard
65	<b>0610-0810</b>	<b>Retaining Ring</b>	<b>HP</b>

FIGURE 6-2. EXPLODED VIEW-CARRIAGE ARM (SHEET 2 OF 2)

## SECTION VII

### TROUBLESHOOTING

#### 7-1. INTRODUCTION

#### 7-2. CONTENT

7-3. This section contains instructions for troubleshooting the Model 7035B. Component location photographs, schematics, and a troubleshooting index are supplied to aid in troubleshooting.

#### 7-4. TROUBLESHOOTING

#### 7-5. REQUIREMENTS

7-6. Troubleshooting should be performed in a logical manner. The concept of bracketing should be established, such as

determining which circuits or sections are not operating or are operating abnormally. This is generally the fastest method to locate trouble in a closed loop circuit. When troubleshooting utilize the photographs and schematics presented in this section, Figures 7-1 through 7-3.

#### 7-7. TROUBLESHOOTING INDEX

7-8. The troubleshooting index, Table 7-1, lists other possible malfunctions, suspected causes, and remedies. Use component location photographs and schematics for backup when searching out a problem area.

TABLE 7-1. 7035B TROUBLESHOOTING INDEX

PROBLEM	POSSIBLE CAUSE	CURE
1. One position of pen produces excessive jitter that repeats each time the pen reaches this position.	"Dirty" slidewire. High contact resistance between slidewire wiper and either resistance element or pickoff strip.	Clean slidewire (see paragraph 5-11).
2. Excessive pen jitter (small amplitude).	<ul style="list-style-type: none"> <li>a. Amplifier gain adjusted too high.</li> <li>b. Strap between front panel guard terminal and negative input terminal disconnected.</li> <li>c. Excessive common mode signal.</li> <li>d. Excessive differential input signal noise.</li> </ul>	<ul style="list-style-type: none"> <li>a. Adjust (lower) gain per paragraph 5-92.</li> <li>b. Connect strap.</li> <li>c. See Table 1-1.</li> <li>d. See Table 1-1.</li> </ul>
3. Excessive Y-axis retrace hysteresis (any slope).	<ul style="list-style-type: none"> <li>e. "Dirty" slidewire.</li> <li>a. Amplifier gain too low.</li> <li>b. Source impedance too high (1 mv/inch, 0.4 mv/cm) range only.</li> <li>c. Drive string too loose. Measure tension per paragraph 5-66.</li> <li>d. Pen carriage wheels set too tight.</li> <li>e. Insufficient backlash in gears (too tight).</li> <li>f. Motor brushes excessively worn.</li> <li>g. Pen speed too fast. Retrace error should be small only at pen speeds below 1 inch/sec.</li> <li>h. Bearing in drive train faulty.</li> <li>i. Faulty neon bulb in photochopper.</li> <li>j. Excessive differential noise on input signal.</li> </ul>	<ul style="list-style-type: none"> <li>e. Clean slidewire (see paragraph 5-11).</li> <li>a. Adjust gain (paragraph 5-92).</li> <li>b. Lower source impedance and/or increase amplifier gain (paragraph 5-92).</li> <li>c. Tighten drive string (paragraph 5-67).</li> <li>d. Adjust pen carriage (per paragraph 5-71).</li> <li>e. Adjust backlash (paragraph 5-69).</li> <li>f. Replace brushes (paragraph 5-38).</li> <li>g. Decrease retrace pen speed.</li> <li>h. Replace bearing.</li> <li>i. Replace bulb (aging not required).</li> <li>j. See Table 1-1.</li> </ul>
4. Excessive X-axis retrace hysteresis (any slope).	<ul style="list-style-type: none"> <li>k. Excessive friction.</li> <li>a. Amplifier gain too low.</li> <li>b. Source impedance too high (1 mv/inch, 0.4 mv/cm) range only.</li> <li>c. Drive belt too loose. Measure per paragraph 5-78.</li> </ul>	<ul style="list-style-type: none"> <li>k. Clean and lubricate per paragraphs 5-9 and 5-13.</li> <li>a. Adjust gain (paragraph 5-92).</li> <li>b. Lower source impedance and/or increase amplifier gain (paragraph 5-92).</li> <li>c. Tighten belt (paragraph 5-79).</li> </ul>

TABLE 7-1. 7035B TROUBLESHOOTING INDEX (Continued)

PROBLEM	POSSIBLE CAUSE	CURE
4. (cont)	<ul style="list-style-type: none"> <li>d. X-axis slider rod bearings too tight.</li> <li>e. Insufficient backlash in gears (too tight).</li> <li>f. Motor brushes excessively worn.</li> <li>g. Pen speed too fast. Retrace error should be small only at pen speeds below 1 inch/sec.</li> <li>h. Bearing in drive train faulty.</li> <li>i. Faulty neon bulb in photochopper.</li> <li>j. Excessive differential noise on input signal.</li> <li>k. Grease on drive belt.</li> </ul>	<ul style="list-style-type: none"> <li>d. Adjust slide rod bearings (paragraph 5-85).</li> <li>e. Adjust backlash (paragraph 5-83).</li> <li>f. Replace brushes (paragraph 5-38).</li> <li>g. Decrease retrace pen speed.</li> <li>h. Replace bearing (paragraph 5-87).</li> <li>i. Replace faulty bulb (aging not required).</li> <li>j. See Table 1-1.</li> <li>k. Clean</li> </ul>
5. Excessive hysteresis in 45 retrace (X and Y steep angle retrace O. K.).	<ul style="list-style-type: none"> <li>a. Source impedance too high or low (1 my/inch range only) causing excessive phase shift in input filter.</li> <li>b. Operating on ranges other than calibrated positions.</li> <li>c. Phase relationship problem in signal source.</li> <li>d. Phase adjustment (R-114) mis-adjusted.</li> <li>e. Pen carriage wheels too loose.</li> </ul>	<ul style="list-style-type: none"> <li>a. Adjust R-114 (paragraph 5-97). This control will adjust the phasing nominal source impedance. Extremes can be compensated for only by reducing the pen speed, thereby reducing the phase shift.</li> <li>b. Possible cures:               <ul style="list-style-type: none"> <li>1. Adjust R-114.</li> <li>2. Reduce pen speed.</li> </ul> </li> <li>c. Examine signal source.</li> <li>d. Adjust R-114 per paragraph 5-97.</li> <li>e. Adjust pen carriage wheels (paragraph 5-71).</li> </ul>
6. Calibration incorrect.	<ul style="list-style-type: none"> <li>a. Calibration controls (front panel screw driver adj) incorrectly adjusted.</li> <li>b. Recording paper inaccurate due to poor printing or environmental effects.</li> </ul>	<ul style="list-style-type: none"> <li>a. Calibrate unit per paragraph 5-95.</li> <li>b. Calibrate unit per paragraph 5-95.</li> </ul>
7. High voltage ranges won't hold calibration.	<p>Leakage on surface of printed circuit board.</p>	<p>Wash board per paragraph 5-9.</p>
8. X-axis arm seems to wobble - not rigidly held. (Slight vertical wobble at zero end of arm is normal.)	<ul style="list-style-type: none"> <li>a. Upper support screws (two) not tight (see figure 5-6).</li> <li>b. X-axis slider rod bearings too loose.</li> </ul>	<ul style="list-style-type: none"> <li>a. Align arm and tighten (see paragraph 5-73).</li> <li>b. Adjust slider rod bearing (paragraph 5-85).</li> </ul>

TABLE 7-1. 7035B TROUBLESHOOTING INDEX (Continued)

<u>PROBLEM</u>	<u>POSSIBLE CAUSE</u>	<u>CURE</u>
8. (cont)	c. Excessive X-axis gear backlash.	c. Adjust backlash (paragraph 5-83).
9. X-axis motor stalls when end of scale stops are hit. (Prolonged operation in this condition may damage motor or amplifier - motor must not stall. )	X drive belt too tight. Measure per paragraph 5-78.	Adjust (loosen) drive belt (paragraph 5-79).
10. Recorder response extremely slow - operating on 1 mv/inch (0.4 mv/cm) range.	Input signal source impedance too high (paragraph 5-92).	Use lower source impedance.
11. Zero position not repeatable during recorder "set-up" - using 1 mv/inch range (0.4 mv/cm).	No source impedance connected to input.	Place resistance across input terminals (+ to -). R to be 20K or less.
12. Pen carriage wobbles causing poor writing.	Pen carriage wheels too loose.	Adjust pen carriage wheels per paragraph 5-71.
13. Y-axis moves in jerks, seems to occasionally bind or stick.	a. Drive string too loose. Measure per paragraph 5-66.	a. Tighten drive string (see paragraph 5-67).
	b. Pen carriage wheels set too tight.	b. Adjust pen carriage per paragraph 5-71.
	c. Insufficient backlash in gears (too tight).	c. Adjust backlash (paragraph 5-69).
	d. Motor brushes excessively worn.	d. Replace brushes (see paragraph 5-38).
	e. Motor brush stuck, held off commutator.	e. Free-up brush (see paragraph 5-40).
	f. Bearing in drive system faulty.	f. Replace bearing.
	g. Excessive mechanical friction. Unit needs general cleaning and lubrication.	g. Clean and lubricate per paragraphs 5-9, 5-12.
14. X-axis moves in jerks, seems to occasionally bind or stick.	a. X-axis slider rod bearings too tight.	a. Adjust slider rod bearings (paragraph 5-85).
	b. X-gear backlash insufficient (too tight).	b. Adjust backlash (paragraph 5-83).
	c. Motor brushes excessively worn.	c. Replace brushes (paragraph 5-38).
	d. Motor brush stuck and therefore held off commutator.	d. See paragraph 5-40.
	e. Bearing in drive train faulty.	e. Replace bearing (paragraph 5-87).
	f. Excessive friction.	f. Clean and lubricate per paragraphs 5-9 and 5-12.

TABLE 7-1. 7035B TROUBLESHOOTING INDEX (Continued)

<u>PROBLEM</u>	<u>POSSIBLE CAUSE</u>	<u>CURE</u>
15. Y-axis acceleration too slow.	a. Drive string too loose. Measure tension per paragraph 5-66. b. Input signal source impedance too high (1 mv/inch, 0.4 mv/cm) range only. c. Bearing in drive train faulty. d. Faulty neon bulb in photochopper. e. Excessive differential noise on input signal. f. Excessive friction.	a. Tighten drive string (see paragraph 5-67). b. Lower source impedance and/or increase amplifier gain (see paragraph 5-92). c. Replace bearing. d. Replace bulb (aging not required). e. See Table 1-1. f. Clean and lubricate per paragraphs 5-9 and 5-12.
16. X-axis acceleration too slow.	a. Drive belt too loose. Measure tension per paragraph 5-78. b. Input signal source impedance too high (1 mv/inch, 0.4 mv/cm) range only. c. Bearing in drive train faulty. d. Faulty neon bulb in photochopper. e. Excessive differential noise on input signal. f. Excessive friction.	a. Tighten drive belt (paragraph 5-79). b. Lower source impedance and/or increase amplifier gain (see paragraph 5-92). c. Replace bearing (see paragraph 5-87). d. Replace bulb (aging not required). e. See Table 1-1. f. Clean and lubricate per paragraphs 5-9 and 5-12.
17. Maximum pen speed too slow.	a. Power line voltage too low. (Pen speed is dependent on line voltage.) b. Operating on 115-vol line with voltage selector switch in 230-volt position (front panel neon won't light). c. Bearing in drive train faulty. d. Faulty neon in photochopper. e. Excessive differential noise on input signal. f. Excessive friction.	a. Increase line voltage (i.e., with Variac). b. Correct switch position. c. Replace bearing. (See paragraph 5-87). d. Replace faulty neon (no aging required). e. See Table 1-1. f. Clean and lubricate per paragraphs 5-9 and 5-12.
18. Excessive Y-axis overshoot.	a. Drive string too loose. Measure tension per paragraph 5-66.	a. Tighten drive string (paragraph 5-67).



TABLE 7-1. 7035B TROUBLESHOOTING INDEX (Continued)

<u>PROBLEM</u>	<u>POSSIBLE CAUSE</u>	<u>CURE</u>
18. (cont)	<ul style="list-style-type: none"> <li>b. Amplifier gain too low.</li> <li>c. Damping capacitor improper value.</li> </ul>	<ul style="list-style-type: none"> <li>b. Adjust amplifier gain (see paragraph 5-92).</li> <li>c. Replace capacitor. Increasing value decreases overshoot.</li> </ul>
19. Excessive X-axis overshoot.	<ul style="list-style-type: none"> <li>a. Drive belt too loose. Measure per paragraph 5-78.</li> <li>b. Amplifier gain too low.</li> <li>c. Damping capacitor improper value.</li> </ul>	<ul style="list-style-type: none"> <li>a. Tighten drive belt (paragraph 5-79).</li> <li>b. Adjust amplifier gain (see paragraph 5-92).</li> <li>c. Replace with proper value capacitor. Increasing value decreases overshoot.</li> </ul>
20. X-axis produces loud, audible noise when moved fast.	X-axis backlash too loose or too tight.	Adjust backlash (paragraph 5-83).
21. Y-axis won't go full scale (stops short by approximately 1/16 inch to 1/4 inch).	<ul style="list-style-type: none"> <li>a. Drive string too tight, causing spring to be over-extended, hitting stop.</li> <li>b. Zero pot wiper resistor improper value (R-120).</li> </ul>	<ul style="list-style-type: none"> <li>a. Loosen drive string (paragraph 5-67).</li> <li>b. Replace resistor.</li> </ul>
22. One axis runs erratically at high speed in one or both directions.	<ul style="list-style-type: none"> <li>a. Motor brush not properly seated to commutator.</li> <li>b. Motor brush tends to "cock" in one direction of rotation and binds in brush holder.</li> </ul>	<ul style="list-style-type: none"> <li>a. Inspect brush. Replace per paragraph 5-38 or "run-in" motor to seat brush.</li> <li>b. Replace motor per paragraphs 5-34 and 5-35.</li> </ul>
23. Slewing one axis causes disturbance on other axis.	<ul style="list-style-type: none"> <li>a. CR-111 open</li> <li>b. Lucite tubes in photochopper uncovered.</li> </ul>	<ul style="list-style-type: none"> <li>a. Replace.</li> <li>b. Cover with fish-paper (see Figure 5-24).</li> </ul>
24. Paper holddown weak.	<ul style="list-style-type: none"> <li>a. Table surface contaminated (see paragraph 5-9).</li> <li>b. Paper surface too rough, insufficient contact area (i.e., parchment or curled film).</li> <li>c. One of the two table power leads disconnected.</li> </ul>	<ul style="list-style-type: none"> <li>a. Wash with soap and water (paragraph 5-9).</li> <li>b. Contact factory.</li> <li>c. Connect lead (Figure 5-24).</li> </ul>
25. Paper holddown inoperative.	Table power leads disconnected.	Connect leads (Figure 5-24).
26. Servo gain varies erratically.	Excessive contact resistance in gain potentiometer R-137 or R-237.	Replace
27. Very erratic operation.	a. Operation on 115-volt line with voltage selector switch in 230 position (front panel neon will not light).	a. Correct switch position.

TABLE 7-1. 7035B TROUBLESHOOTING INDEX (Continued)

<u>PROBLEM</u>	<u>POSSIBLE CAUSE</u>	<u>CURE</u>
27. (cont)	b. Bearing in drive train faulty. c. Motor brushes excessively worn. d. Motor brush stuck, held off commutator. e. Excessive friction.	b. Replace bearing (paragraph 5-87). c. Replace brushes (see paragraph 5-38). d. See paragraph 5-39. e. Clean and lubricate per paragraphs 5-9 and 5-12.
28. Common mode rejection poor.	a. Guard strap disconnected. b. Guard not connected directly to common mode source. c. Source impedance unbalance too high.	a. Connect strap. b. Remove guard strap and connect guard input to source. c. See Table 1-1.
29. One axis motor will not respond to input signal. (Gears and motor mechanically free and electronics providing proper drive signal to motor).	a. Motor brushes excessively worn, b. Motor brush stuck, held off commutator.	a. Replace brushes (see paragraph 5-38). b. Free-up brush (see paragraph 5-39).
30. Recorder dives hard to end of scale, will not balance.	a. Faulty slidewire wiper. b. Open In balance circuit. c. Phase reversal in servo system (common occurrence during repair work).	a. Replace wiper (see paragraphs 5-26 and 5-30). b. Check balance circuits in fig. 7-3 to locate faulty components. c. Correct by reversing wires on servo motor.
31. Recorder completely dead (Autogrip inoperative, power neon indicator inoperative).	a. Fuse blown. b. 115 volt/230 volt switch in 230 volt position when powered on 115 volts.	a. Locate and correct cause of blown fuse. Replace fuse. b. Correct switch position.
32. Recorder dead (Auto-grip operates, power neon indicator operates).	Neon bulbs in photochopper not lit. Fault in neon power supply.	Check voltages in neon power supply.

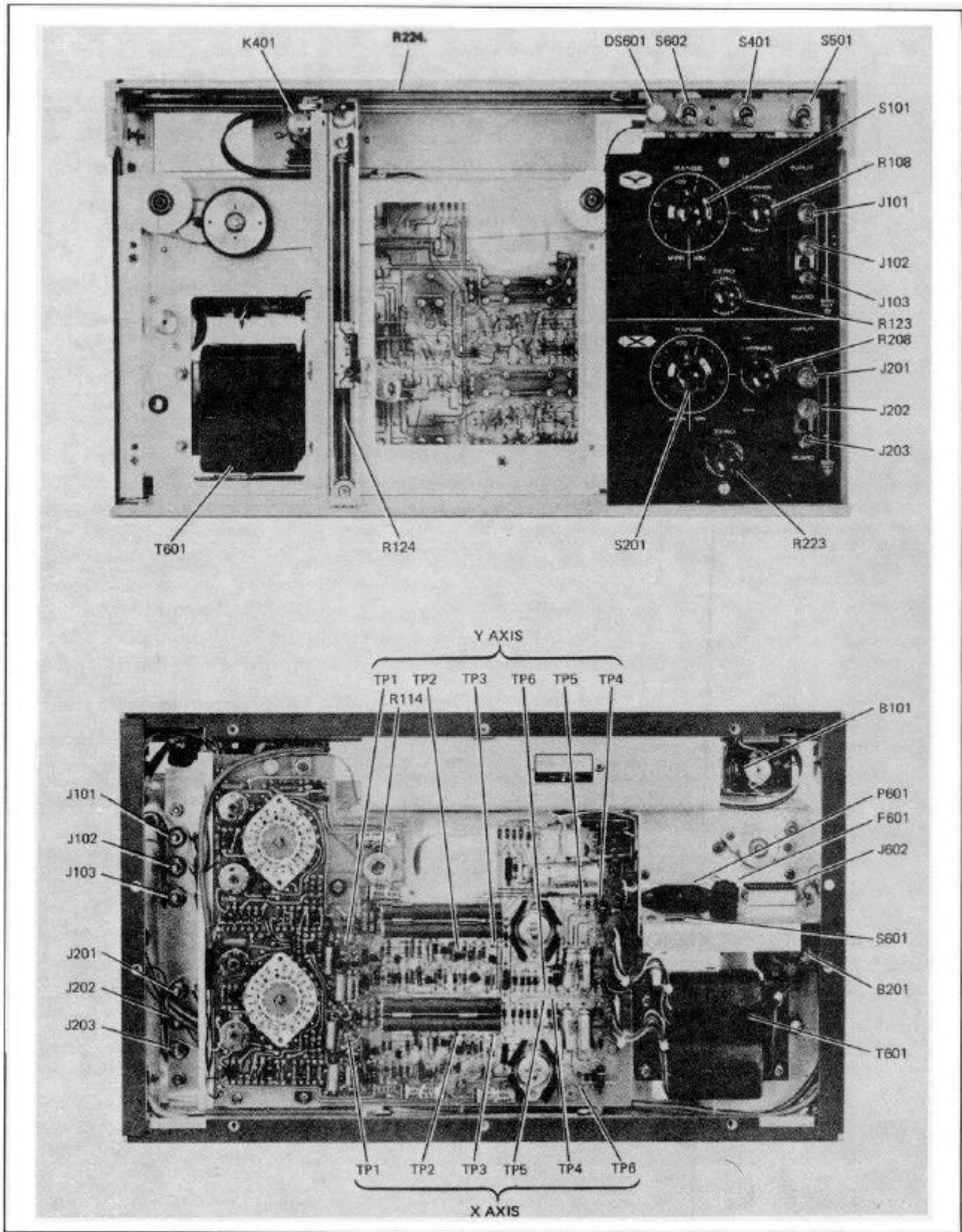

FIGURE 7-1. COMPONENT IDENTIFICATION-FRAME

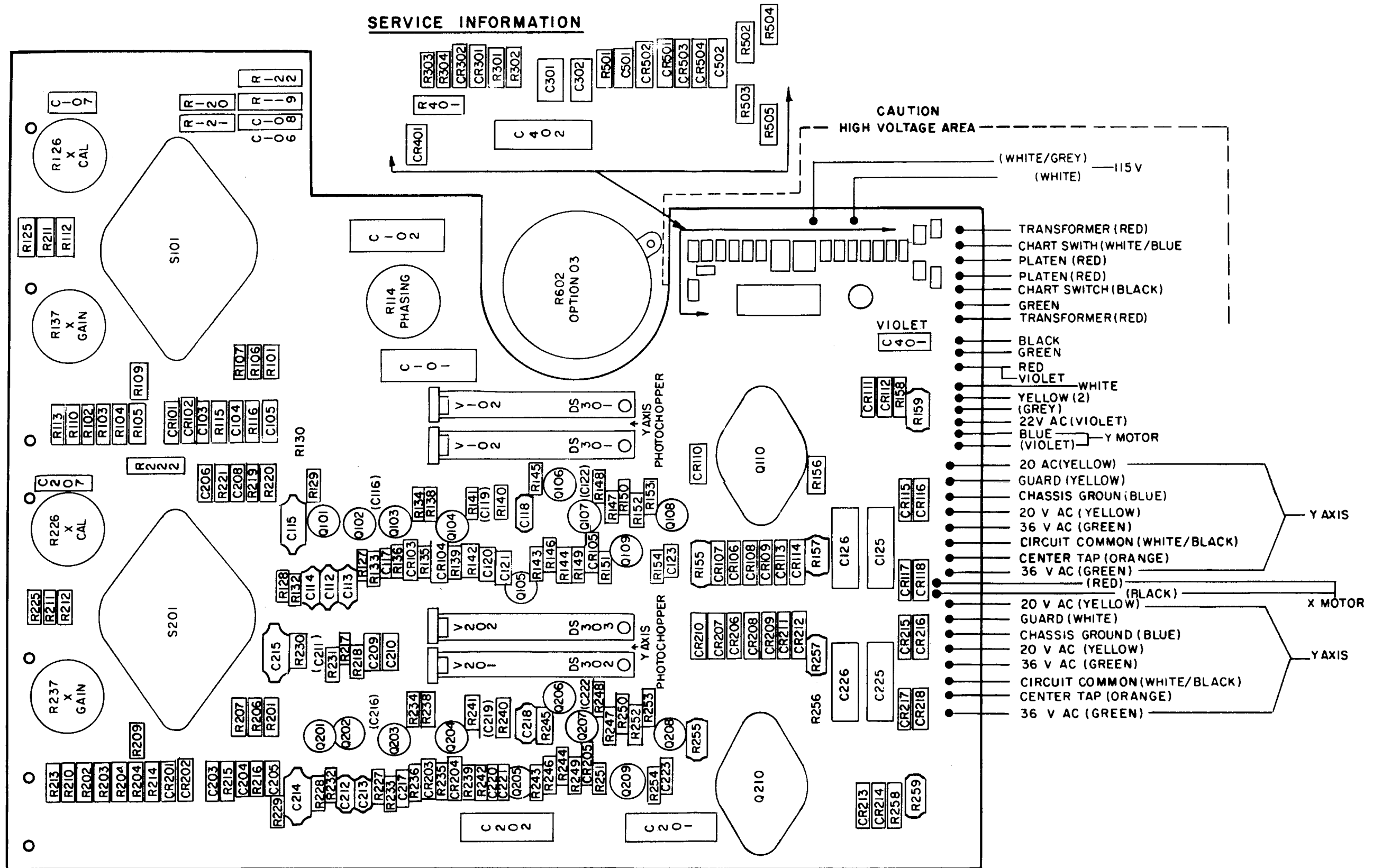

Figure 7-2. Component Identification - Circuit Board.

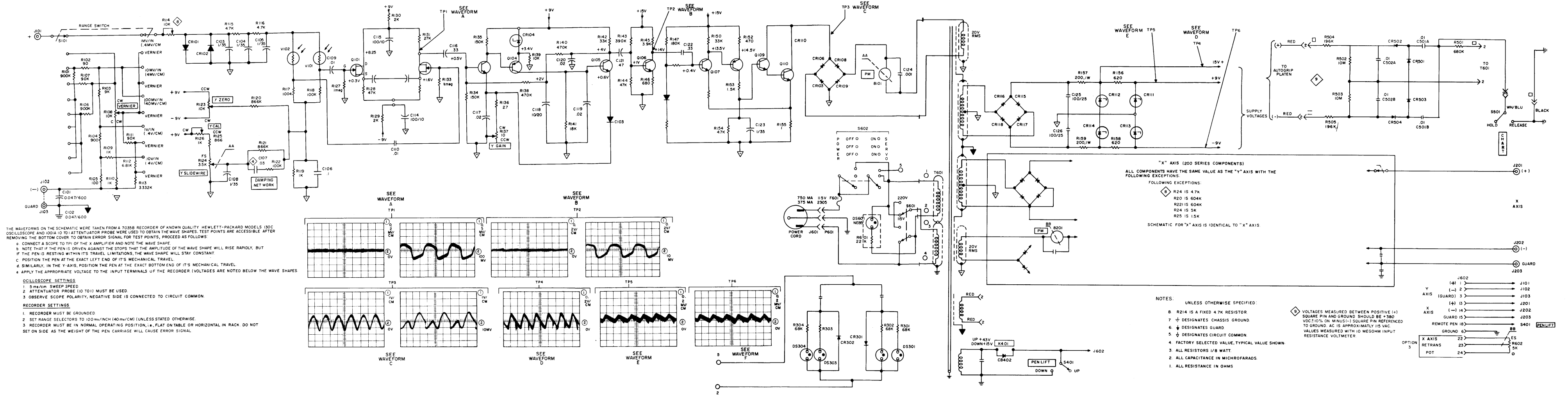

Figure 7-3. Schematic Model 7035B (D-07035-92550).

**SECTION VIII**

**BACKDATING**

**8-1. REQUIREMENTS**

8-2. DEFINITIONS

8-3. This section provides information on serial prefixes below 845. Table 8-1 is a tabular presentation of the serial prefix numbers and the corresponding change numbers. To adapt this manual to the instrument on hand, determine the serial prefix of the instrument, then refer to Table 8-1 and make the appropriate changes to the manual.

*TABLE 8-1. SERIAL PREFIX/CHANGE NUMBER REFERENCES*

Serial Prefix	Change
1113A-1049A	I
1048A-1040A	I, II
1039A-1025A	I, II, III
1024A-1017A	I, II, III, IV
1016A-926	I thru V
925-845	I thru VI
844 and Below	I thru VII

8-4. CHANGE I

8-5. COLOR SCHEME. Page 1-3, Figure 1-4, change trim to Light Gray.

Page 2-2, Figure 2-1, change Rack Mount Brackets part no. to 07035-00490.

Page 6-3, Table 6-1, change J-601 part no. to 8120-3148.

Page 6-6, Table 6-2, Spare Parts, change the following items: Power Cord, 8120-1348; Panel - Side - RH & LH, 07035-00071; Panel - Front and Rear, 07035-00061; Rear Hood Assy - Stnd, 07035-62570; Rear Hood Assy - Metric, 07035-62571.

Page 6-11, Figure 6-2, items 47 and 48 part no.'s are: 47 Block, Pen Arm, 07034-60320; 48 Pen Scale Assy - Eng, 07034-60210 and Pen Scale Assy - Met - 07034-60200

Page 6-9, Figure 6-1, make the following changes: Pen Scale - Eng, 07034-60210; Pen Scale - Met, 07034-60200; Rear Hood Assy - Eng, 07035-62570; Rear Hood - Met, 07035-62571; Panel Rear, 07035-00061; Panel RH, 07035-00071; Rear Corner - RH, 07035-40030; Front Corner - RH, 07035-20150; Rear Corner - LH, 07035-40040; Panel - Front, 07035-00061; Front Corner - LH, 07035-40021; and Panel - LH, 07035-00071.

Page 7-9, Figure 7-2, use the following Component ID illustration:

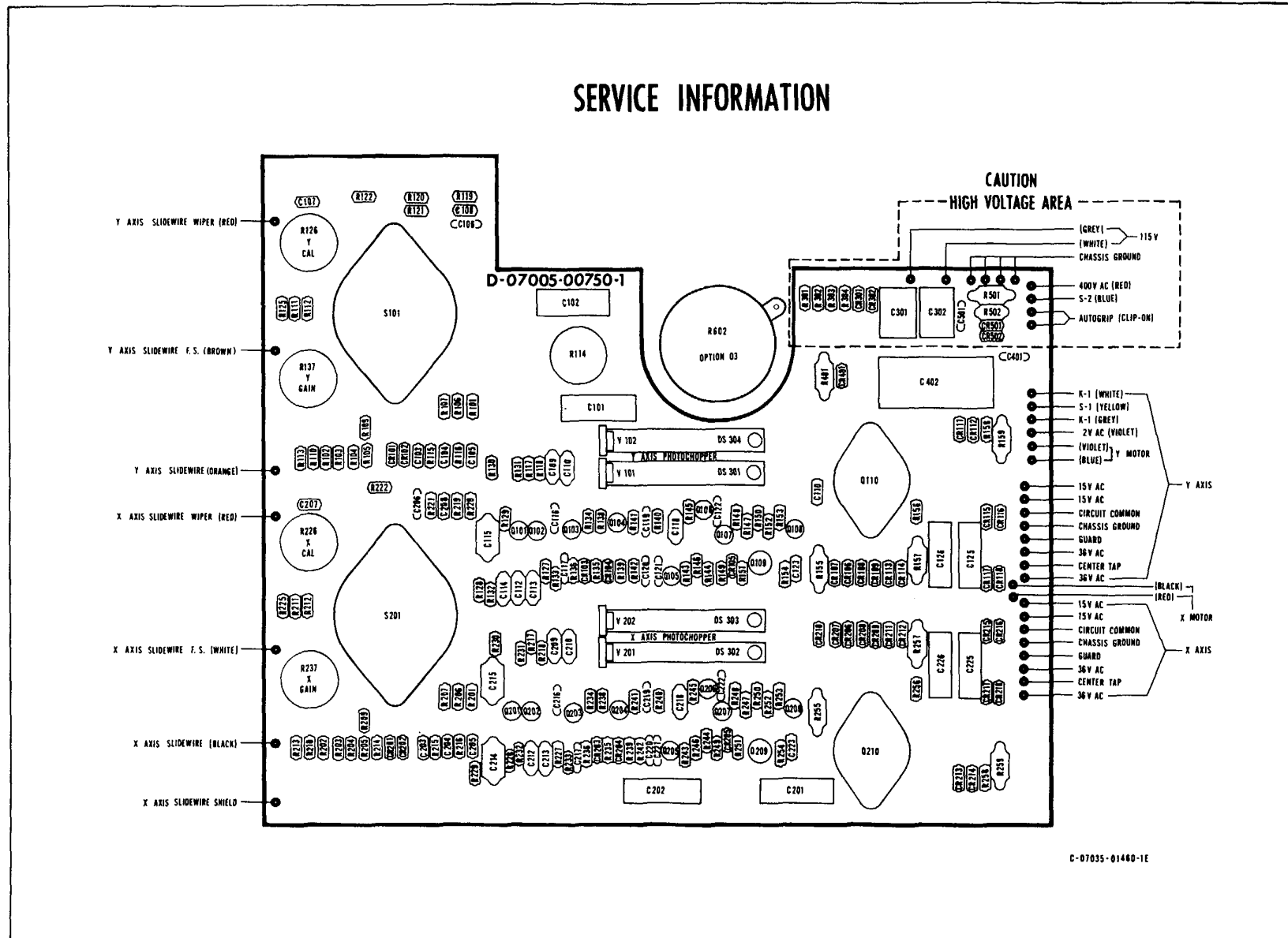

FIGURE 8-1. COMPONENT IDENTIFICATION - CIRCUIT BOARD

8-6. CHANGE II

8-7. IEC. Page. All photos and illustrations of Front Panel will appear as shown:

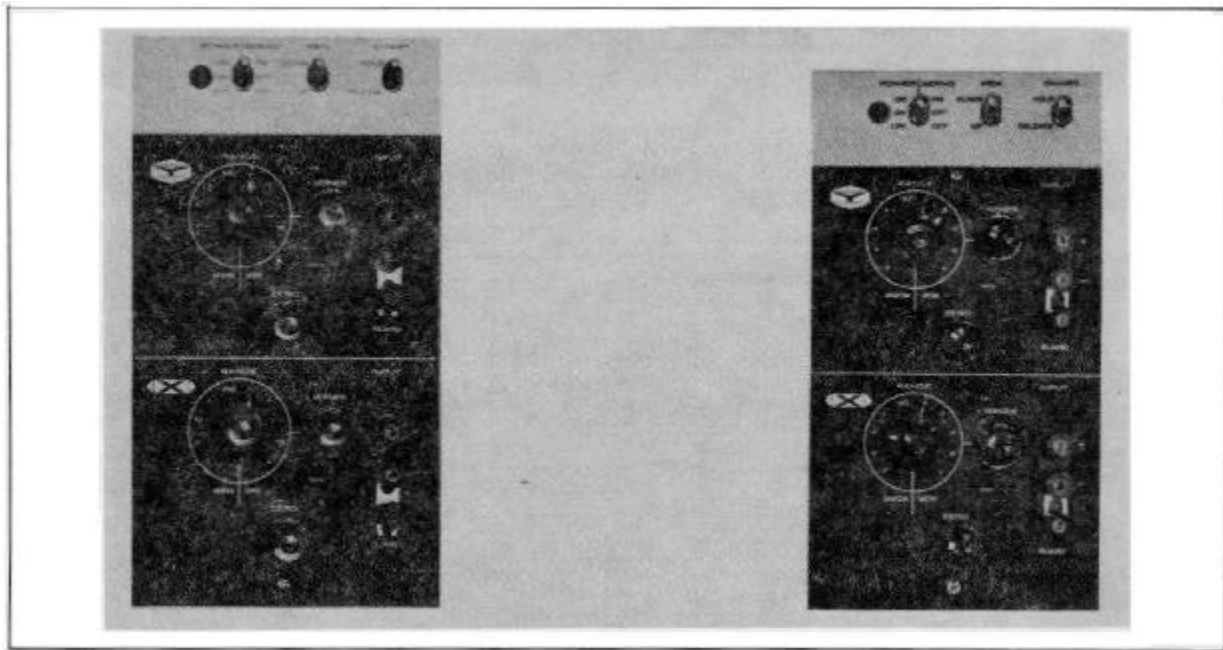

FIGURE 8-2. CONTROL PANELS - MODEL 7035B AND 7035B-001

Delete IEC from Rear Connector.

8-8. CHANGE III

8-9. IEC. Page 6-3, Table 6-1, change DS601 and F601 to read:

DS601	1450-0123	Indicator Light	08717 Sloan	859-R-6
F601	2110-0063	Fuse, 0.75A, 2A 250v	75915 Littlefuse	312.750
	1400-0085	Holder - Fuse	75915 Littlefuse	342004

Page 6-3, Table 6-1, change J601 and P601 to read:

J601	8120-0078	Power Cord	0903 Belden	KH-4147
P601	12 51-0148	Connector, AC Power	87930 Tower Mfg	1065-1

Page 6-5, Table 6-1, change S601 to read:

S601	3101-0033	Switch, Slide (Power Conversion)	79727 Continental	6510C
------	-----------	----------------------------------	----------------------	-------

Page 6-6, Table 6-2, change Power Cord to read:

	8120-0078	Power Cord	70903 Belden Corp	KHS-7041
--	-----------	------------	----------------------	----------



Page 6-7, Table 6-3, change DS 601 and F601 to read:

DS601	1450-0123	Indicator Light	08717 Sloan	859-R-6
F601	2110-0063	Fuse, 0.75A, 2A 250V	75915 Littlefuse	312.750
	1400-0085	Holder -Fuse	75915 Littlefuse	342004

Page 7-9, Figure 7-3, make the following change to the schematic:

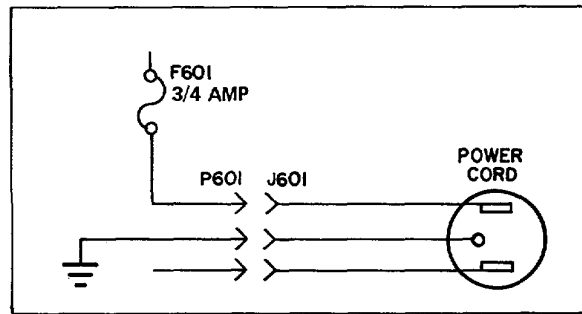

FIGURE 8-3. IEC POWER CONNECTION

Shielded 4-conductor cable and 3 additional color coded wires (white/blue, black and yellow) are replaced by a shielded 7-conductor cable assembly. Pre-IEC receptacle for ac power connector also used.

8-10. CHANGE IV

mating connector, appropriate graph paper, power cord (7.5 ft), rack mounting brackets, dust cover, instruction manual.

8-11. CARRIAGE ARM. Page 6-11, Figure 6-2, Legend, delete, item 29, delete part no. for terminal

Page 3-4, paragraph 3-34, 3-35, and Figure 3-3, replace with:

8-12. CHANGE V

3-34. INSTALL AN INK PEN

8-13. PEN ASSEMBLY. Page 1-4, Table 1-2, should include the following: Slidewire cleaner, slidewire lubricant, 2 pens, 1 btl green ink, 1 btl red ink, ink filling, syringe, rear

3-35. Use a hypodermic syringe; fill reservoir just short of full. Force ink into the pen tip by fully inserting the syringe into the filler opening and squeeze gently. See Figure 8-4.

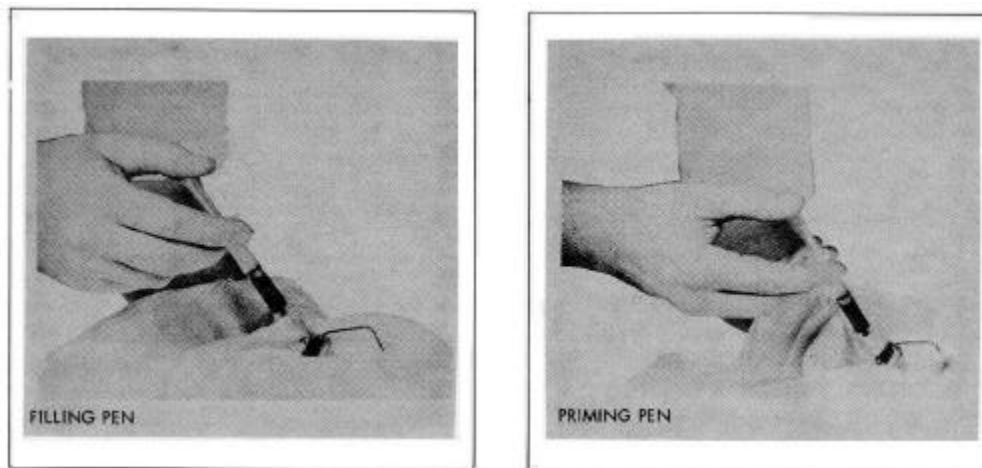

FIGURE 8-4. FILLING INK PEN

Page 4-1, add new paragraphs 4-6A and 4-6B to read:

4-6A. PEN SYSTEM

4-6B. The pen assembly consists of a drum type reservoir resting in a pivot mount which moves along the carriage arm. A rigid capillary tube feedline leads from the reservoir to the pen point. Because of the capillary process, rack mounted (vertical) models write equally well as the table models. The pen should never be allowed to run dry.

ink stops flowing. Pen assemblies should be cleaned thoroughly every two to four weeks. Clean by soaking in alcohol or hot water. Clogging during operation may be cleared by one or more of the following steps:

- a. Using the furnished syringe, apply air pressure to the reservoir's ink filler hole.
- b. Soak pen assembly in alcohol or hot water.
- c. Internally clean tip by inserting the stiff wire supplied in accessory kit.
- d. Prior to extended storage, flush and clean pen.

Page 5-3, add new paragraphs 5-18A and 5-18B to read:

5-18A. PEN MAINTENANCE

5-18B. Pen writing failures may be caused by dried ink, sediment, air bubbles in feed line, or general neglect. Dirt and ink sediment cause the most difficulty. Dried ink forms brittle crust particles which, together with dirt, build up in the supply line until the

**CAUTION Care must be taken not to touch pen tip with fingers or any greasy substance.**

Page 6-6, Table 6-2, Mechanical, Electric, add 17999-15126, Pen Cleaning Wire, H-P, 17999-15126.

Page 6-6, Table 6-2, Accessory Kit, Paper, Ink, change to read as follows:

17999-09423 9260-0128 9260-0127	Syringe (Pen filler) Ink, Red Ink, Blue	H-P	17999-09473
9270-1006 9270-1007 9270-1023	Chart Paper, Standard (heavy) Chart Paper, Standard (light) Chart Paper, Metric (heavy)	Gubelman Gubelman Gubelman	H-10070/A L-10070/A
9270-1027 07035-80630 07035-81030	Chart Paper, Metric (light) Pen Assy Pen Accessory Kit	Gubelman H-P H-P	07035-80630 07035-81030
5950-2587	Maintenance brochure	H-P	5950-2587

Page 6-7, Table 6-3, Spare Parts, change K401 to:

07035-60140	Solenoid, Pen Lift	H-P	07035-60140
07035-60120	Plunger Assy, Solenoid	H-P	07035-60120

Page 6-7, Table 6-3, Spare Parts, delete Pen Holder, add:

07035-80630	Pen Assembly	H-P	07035-80630
-------------	--------------	-----	-------------

Page 6-10, Figure 6-2 (Illustration) is changed as shown in Figure 8-5.

Page 6-11, Figure 6-2 (Legend) make the following changes:

12	14600722	Spring, Pen Lift	Superior Spring
47	07035-41820	Block, Pen Arm	H-P
48	0703560185	Pen Scale Assy - Blank Scale	H-P
	07035-60186	Pen Scale Assy - English Scale	H-P
	07035-60250	Pen Scale Assy - Metric Scale	H-P
54	07035-61120	Pen Holder Assy (all Serial Prefixes before 803)	H-P
	07035-60070	Pen Holder Assy (Serial Prefix 803 and later without disposable pen)	H-P
56	07035-61410	Pen Lift Assy	H-P
58	07035-60140	Solenoid Assy (Below S/P 826 requires index point 07005-00730)	H-P
60	07035-62210	Plunger, Solenoid Assy	H-P
61	07035-80630	Pen Assy	H-P

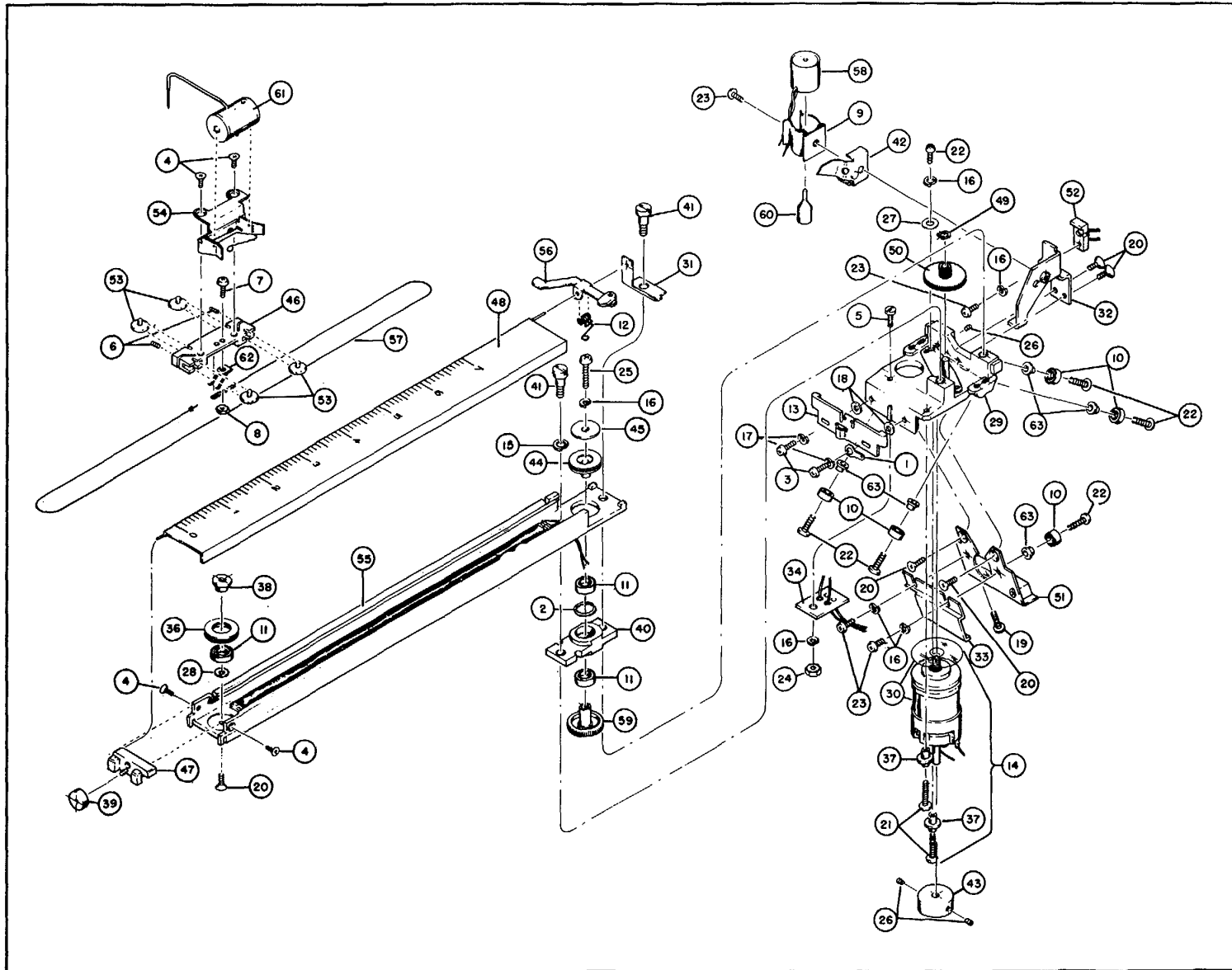

FIGURE 8-5. EXPLODED VIEW - CARRIAGE ARM

Page 6-9, Figure 6-1, change PEN SCALE part no.'s to:

BLANK 07035-60185    ENGLISH 07035-60186    METRIC 07035-60250

Page 7-7, Table 7-1, new item 33 to read:

- |                     |  |  |
|---------------------|--|--|
| 33. Pen won't write | a. Pen tip clogged.<br>b. Pen reservoir empty. | a. See paragraph 5-18B.<br>b. Fill with ink (See Figure 3-3.). |
|---------------------|--|--|

8-14. CHANGE VI

8-15. X CAL. Page 6-5, Table 6-1, change R-225 to:

R-225	0698-3250	Resistor, Mtl Flm, 1.71k 1%, 1/8W	Int'l Resist.	CEA T-2.
-------	-----------	-----------------------------------	---------------	----------

Page 7-9, Figure 7-3, X AXIS BLOCK, change value of R225 to 1.71k.

Page 6-11, Figure 6-2 (Legend), change item 48 to read:

8-16. CHANGE VII

48	0035-60180 07035-60181 07035-60182	Pen Scale Assy - Blank Pen Scale Assy - English Pen Scale Assy - Metric
----	--	---

8-17. COLOR SCHEME. Page 1-3, Figure 1-4, change trim to aluminum.

Page 6-9, Figure 6-1, change the following:

PEN SCALE BLANK 07035-60180; ENGLISH 07035-60181; METRIC 07035-60182

REAR HOOD ASSY ENGLISH 07035-60020; METRIC 07035-60021

**APPENDIX A**  
**REFERENCES**

---

DA Pam 310-4  
TM 38-750  
TM 750-244-2

Index of Technical Publications.  
The Army Maintenance Management System (TAMMS).  
Procedures for Destruction of Electronics Materiel to Prevent Enemy Use (Electronics Command).

## APPENDIX B

## MAINTENANCE ALLOCATION

## Section I. INTRODUCTION

**B-1. General**

This appendix provides a summary of the maintenance operations for the RO-458(V)1/U. It authorizes categories of maintenance for specific maintenance functions on repairable items and components and the tools and equipment required to perform each function. This appendix may be used as an aid in planning maintenance operations.

**B-2. Maintenance Function**

Maintenance functions will be limited to and defined flows:

- a. *Inspect.* To determine the serviceability of an item by comparing its physical, mechanical, and/or electrical characteristics with established standards through examination.
- b. *Test.* To verify serviceability and to detect incipient failure by measuring the mechanical or electrical characteristics of an item and comparing those characteristics with prescribed standards.
- c. *Service.* Operations required periodically to keep an item in proper operating condition, i.e., to clean (decontaminate), to preserve, to drain, to paint, or to replenish fuel, lubricants, hydraulic fluids, or compressed air supplies.
- d. *Adjust.* To maintain, within prescribed limits, by bringing into proper or exact position, or by setting the operating characteristics to the specified parameters.
- e. *Align.* To adjust specified variable elements of an item to bring about optimum or desired performance.
- f. *Calibrate.* To determine and cause corrections to be made or to be adjusted on instruments or test measuring and diagnostic equipments used in precision measurement. Consists of comparisons of two instruments, one of which is a certified standard of known accuracy, to detect and adjust any discrepancy in the accuracy of the instrument being compared.
- g. *Install.* The act of emplacing, seating, or fixing into position an item, part, module (component or assembly) in a manner to allow the proper functioning of the equipment or system.
- h. *Replace.* The act of substituting a serviceable like type part, subassembly, or module (component or assembly) for an unserviceable counterpart.
- i. *Repair.* The application of maintenance services (inspect, test, service, adjust, align, calibrate, replace) or other maintenance actions (welding, grinding, riveting, straightening, facing, remachining, or resurfacing) to restore serviceability to an item by correcting specific damage, fault, malfunction, or failure in a part, subassembly, module (component or assembly), end item, or system.
- j. *Overhaul.* That maintenance effort (service/action) necessary to restore an item to a completely serviceable/operational condition as prescribed by maintenance standards (i.e., DMWR) in appropriate technical publications. Overhaul is normally the highest degree of maintenance performed by the Army. Overhaul does not normally return an item to like new condition.
- k. *Rebuild.* Consists of those services/actions necessary for the restoration of unserviceable equipment to a like new condition in accordance with original manufacturing standards. Rebuild is the highest degree of materiel maintenance applied to Army equipment. The rebuild operation includes the act of returning to zero those age measurements (hours, miles, etc.) considered in classifying Army equipments/components.

**B-3. Column Entries**

- a. *Column 1, Group Number.* Column 1 lists group numbers, the purpose of which is to identify components, assemblies, subassemblies, and modules with the next higher assembly.
- b. *Column 2, Component/Assembly.* Column 2 contains the noun names of components, assemblies, subassemblies, and modules for which maintenance is authorized.
- c. *Column 3, Maintenance Functions.* Column 3 lists the functions to be performed on the item listed in column 2. When items are listed without maintenance functions, it is solely for purpose of having the group numbers in the MAC and RPSTL coincide.

d. *Column 4, Maintenance Category.* Column 4 specifies, by the listing of a "work time" figure in the appropriate subcolumn(s), the lowest level of maintenance authorized to perform the function listed in column 3. This figure represents the active time required to perform that maintenance function at the indicated category of maintenance. If the number or complexity of the tasks within the listed maintenance function vary at different maintenance categories, appropriate "work time" figures will be shown for each category. The number of task-hours specified by the "work time" figure represents the average time required to restore an item (assembly, subassembly, component, module, end Item or system) to a serviceable condition under typical field operating conditions. This time includes preparation time, troubleshooting time, and quality assurance/quality control time in addition to the time required to perform the specific tasks identified for the maintenance functions authorized in the maintenance allocation chart. Subcolumns of column 4 are as follows:

- C-Operator/Crew
- O-Organizational
- F-Direct Support
- H-General Support
- D-Depot

e. *Column 5, Tools and Equipment.* Column 5 specifies by code those common tool sets (not individual tools) and special tools, test, and support equipment required to perform the designated function.

f. *Column 6, Remarks.* Column 6 contains an alphabetic code which leads to the remark in section IV, Remarks, which is pertinent to the Item opposite the particular code.

#### **B-4. Tool and Test Equipment Requirements (Sect. III)**

a. *Tool or Test Equipment Reference Code.* The numbers in this column coincide with the numbers used in the tools and equipment column of the MAC. The numbers indicate the applicable tool or test equipment for the maintenance functions.

b. *Maintenance Category.* The codes in this column indicate the maintenance category allocated the tool or test equipment.

c. *Nomenclature.* This column lists the noun name and nomenclature of the tools and test equipment required to perform the maintenance functions.

d. *National/NATO Stock Number.* This column lists the National/NATO stock number of the specific tool or test equipment.

e. *Tool Number.* This column lists the manufacturer's part number of the tool followed by the Federal Supply Code for manufacturers (5-digit) in parentheses.

#### **B-5. Remarks (Sect. IV)**

a. *Reference Code.* This code refers to the appropriate item in section II, column 6.

b. *Remarks.* This column provides the required explanatory information necessary to clarify items appearing in section II.

**(Next printed page is B-5)**

**SECTION II MAINTENANCE ALLOCATION CHART  
FOR  
RECORDER R0-458(V)1/U (HP MODEL 70358)**

(1) GROUP NUMBER	(2) COMPONENT/ASSEMBLY	(3) MAINTENANCE FUNCTION	(4) MAINTENANCE CATEGORY					(5) TOOLS AND EQPT.	(6) REMARKS
			C	O	F	H	D		
0	RECORDER R-458(V)1/U (HP MODEL 7035B)	Inspect		0.2				5,6	A
		Test		0.2				5,6	A
		Test			0.5			5,6	B
		Service			0.3			5,6	
		Adjust				0.3		1,3,5,6	
		Align				0.4		1,2,3,4 thru 6	
		Calibrate				0.5		1,2,3,4 thru 6	
		Replace			0.3			5,6	C
		Repair			0.4			5,6	D
		Repair				0.5		1,2,3,4 thru 6	E
		Overhaul					2.0	1,2,3,4 thru	E



**SECTION III TOOL AND TEST EQUIPMENT REQUIREMENTS  
FOR  
RECORDER R0-458(V)1/U**

TOOL OR TEST EQUIPMENT REF CODE	MAINTENANCE CATEGORY	NOMENCLATURE	NATIONAL/NATO STOCK NUMBER	TOOL NUMBER
1	F, H, D	DC VOLTAGE STANDARD ME-161/U	6625-00-131-3765	
2	F, H, D	FUNCTION GENERATOR HP 330A	6625-00-466-0586	
3	F, H, D	DC VOLTMETER AN/USM-77	6625-00-969-4105	
4	F, H, D	LOW FREQUENCY FUNCTION GENERATOR AN/URM-181	6625-00-983-6712	
5	O, F, H, D	TOOL KIT, ELECTRONIC EQUIPMENT TK-100/G	5180-00-605-0079	
6	O, F, H, D	TOOL KIT, ELECTRONIC EQUIPMENT TK-105/G	5180-00-610-8177	

SECTION IV. REMARKS

REFERENCE CODE	REMARKS
<p>A B C D E</p>	<p>ROUTINE PREVENTIVE MAINTENANCE INSPECTIONS AND OPERATIONAL TEST.            DETAILED TESTING.            LIMITED TO PENS AND PEN CARRIAGE DRIVE CORDS.            LIMITED TO REPAIR OF PEN CARRIAGE DRIVE CORDS.            ALL MECHANICAL AND ELECTRONIC COMPONENTS.</p>

RECOMMENDED CHANGES TO EQUIPMENT TECHNICAL PUBLICATIONS



THEN... JOT DOWN THE DOPE ABOUT IT ON THIS FORM. CAREFULLY TEAR IT OUT. FOLD IT AND DROP IT IN THE MAIL!

SOMETHING WRONG WITH THIS PUBLICATION?

FROM: (PRINT YOUR UNIT'S COMPLETE ADDRESS)

Commander  
Stateside Army Depot  
ATTN: AMSTA-US  
Stateside, N.J. 07703

DATE SENT

10 July 1975

PUBLICATION NUMBER

TM 11-5840-340-12

PUBLICATION DATE

23 Jan 74

PUBLICATION TITLE

Radar Set AN/PRC-76

BE EXACT... PIN-POINT WHERE IT IS

PAGE NO.	PARA-GRAPH	FIGURE NO.	TABLE NO.
2-25	2-28		
3-10	3-3		3-1
5-6	5-8		
		F03	

IN THIS SPACE TELL WHAT IS WRONG AND WHAT SHOULD BE DONE ABOUT IT:

Recommend that the installation antenna alignment procedure be changed throughout to specify a 2° IFF antenna lag rather than 1°

REASON: Experience has shown that with only a 1° lag, the antenna servo system is too sensitive to wind gusting in excess of 25 knots, and has a tendency to rapidly accelerate and decelerate as it hunts, causing strain to the drive train. Hunting is minimized by adjusting the lag to 2° without degradation of operation.

Item 5, Function column. Change "2 db" to "3db."

REASON: The adjustment procedure the the TRANS POWER FAULT indicator calls for a 3 db (500 watts) adjustment to light the TRANS POWER FAULT indicator.

Add new step f.1 to read, "Replace cover plate removed in step e.1, above."

REASON: To replace the cover plate.

Zone C 3. On J1-2, change "+24 VDC to "+5 VDC."

REASON: This is the output line of the 5 VDC power supply. +24 VDC is the input voltage.

PRINTED NAME, GRADE OR TITLE, AND TELEPHONE NUMBER

SSG I. M. DeSpirito 999-1776

SIGN HERE

DA FORM 2028-2  
1 JUL 79

PREVIOUS EDITIONS ARE OBSOLETE.

PS--IF YOUR OUTFIT WANTS TO KNOW ABOUT YOUR RECOMMENDATION MAKE A CARBON COPY OF THIS AND GIVE IT TO YOUR HEADQUARTERS

TEAR ALONG PERFORATED LINE

RECOMMENDED CHANGES TO EQUIPMENT TECHNICAL PUBLICATIONS



THEN...JOT DOWN THE DOPE ABOUT IT ON THIS FORM. CAREFULLY TEAR IT OUT, FOLD IT AND DROP IT IN THE MAIL.

SOMETHING WRONG WITH THIS PUBLICATION?

FROM: (PRINT YOUR UNIT'S COMPLETE ADDRESS)

DATE SENT

PUBLICATION NUMBER

TM 11-6625-2850-14&P

PUBLICATION DATE

18 MAR 1982

PUBLICATION TITLE

Recorder R0-458(V)1/U

BE EXACT PIN-POINT WHERE IT IS

PAGE NO.	PARA-GRAPH	FIGURE NO.	TABLE NO.

IN THIS SPACE TELL WHAT IS WRONG AND WHAT SHOULD BE DONE ABOUT IT:

TEAR ALONG PERFORATED LINE

PRINTED NAME GRADE OR TITLE AND TELEPHONE NUMBER

SIGN HERE

DA FORM 2028-2  
1 JUL 79

PREVIOUS EDITIONS ARE OBSOLETE

P.S.--IF YOUR OUTFIT WANTS TO KNOW ABOUT YOUR RECOMMENDATION MAKE A CARBON COPE OF THIS AND GIVE IT TO YOUR HEADQUARTERS.

REVERSE OF DA FORM 2028-2

FILL IN YOUR  
UNIT'S ADDRESS

FOLD BACK

DEPARTMENT OF THE ARMY

\_\_\_\_\_  
\_\_\_\_\_

OFFICIAL BUSINESS  
PENALTY FOR PRIVATE USE \$300

POSTAGE AND FEES PAID  
DEPARTMENT OF THE ARMY  
DOD 314



TEAR ALONG PERFORATED LINE

Commander  
US Army Communications-  
Electronics Command  
ATTN: DRSEL-ME-MQ  
Fort Monmouth, New Jersey 07703

By Order of the Secretary of the Army:

Official:

**E. C. MEYER**  
*General, United States Army*  
*Chief of Staff*

**ROBERT M. JOYCE**  
*Brigadier General, United States Army*  
*The Adjutant General*

Distribution:

To be distributed in accordance with Special List.

